

Safety notes

- ▶ The Long Range Laser is to be used for measurements in industrial environments. Care must be taken to ensure that the instrument is not subjected to mechanical knocks. It must be operated only by properly trained personnel. No liability will be assumed when components or operating procedures, as described in this guide, are not used as indicated, or are altered without permission of the manufacturer.

Laser safety



- ▶ Do not look directly into the laser beam at any time.
- ▶ Do not insert any optical devices into the beam path.
- ▶ The red LED next to the 'On/Off' switch blinks whenever the laser beam is emitted, lighting steady if the beam finder is switched on.

Service and care

- ▶ Although the Long Range Laser is essentially maintenance free, its calibration accuracy should be checked every two years as indicated by the coloured date wheel label on the side of the Long Range Laser.

Labelling

- ▶ The labels shown below are to be found on the Long Range Laser.



The above laser warning label is affixed on the housing of ALI 4.100.

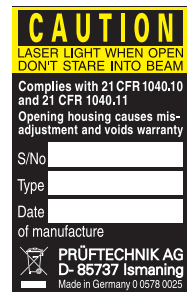

This identification label is affixed on the back side of the Long Range Laser.

A red marking on the Long Range Laser just above the calibration label show the month in which calibration is due. The year is denoted by the date below the db logo.



The above laser warning label is affixed on the housing of ALI 4.100-IS.

Package contents

Contents of the Long Range Laser package ALI 4.120 / ALI 4.120-IS	
ALI 4.100 [or ALI 4.100-IS]	Long Range Laser
ALI 4.112	Mounting base plate
ALI 4.507-2	Long Range laser power cable
ALI 16.600	Long Range Laser power box
0 0741 6071	4 No. M6 x 25 mm hex head screws
0 0741 6069	2 No. M6 x 16 mm hex head screws
0 0620 0008	2 No. magnetic foot adapter
0 0741 6089	2 No. M8 x 12 mm hex head screws
0 0739 1058	5 mm allen key
0 0739 1059	6 mm allen key
DOC 04.101.en	Long Range Laser pocket guide
ALI 9.494.G	Long Range Laser quality certificate
ALI 4.836	Long Range Laser case with insert
ALI 16.610	Li-Ion power box (optional)

Technical data

Laser	
Details	Type: Ga-Al-As semiconductor laser
	Beam divergence: 0.2 mrad
	Laser range: up to 50 m depending on sensor
	Adjustment range: Offset ± 3 mm in X and Y Angular $\pm 3^\circ$ in X and Y
	Adjustment accuracy: 0.002 mm
	Environmental protection: Electrical components IP 65 Mechanical components IP 20
	Beam power: < 1 mW
	Wavelength (typical) 675 nm [for ALI 4.100] or 635 nm [for ALI 4.100-IS] (red, visible)
	Beam diameter: 8 mm
	Safety class: Class 2, FDA 21 CFR 1000 and 1040
	Safety precaution: Do not look into laser beam
	Power supply: 9 V block battery housed in the power box
	Storage temperature: -20°C to 80°C [-4°F to 176°F]
	Operating temperature: -10°C to 50°C [14°F to 122°F]
	Dimensions: approx. 90 x 90 x 150 mm [BxWxL]
	Weight: approx. 820 g [1.8 lb]
Carrying case	
Details	Standard: ABS, drop tested 2 m [6 1/2 ft])
	Dimensions: approx. 400 x 330 x 170 mm

Contact

PRÜFTECHNIK
Condition Monitoring GmbH
Oskar-Messter-Str. 19 – 21
85737 Ismaning
Germany

Tel +49.89.99616-0
Fax +49.89.99616-300
info@pruftechnik.com
www.pruftechnik.com



Long Range Laser

Pocket guide



Know your Long Range Laser

The Long Range Laser is applied in industrial environments to measure large machinery and plants. The laser has a range of 50 m. The four micrometer screws are used to fine adjust the lateral and horizontal position of the laser beam.

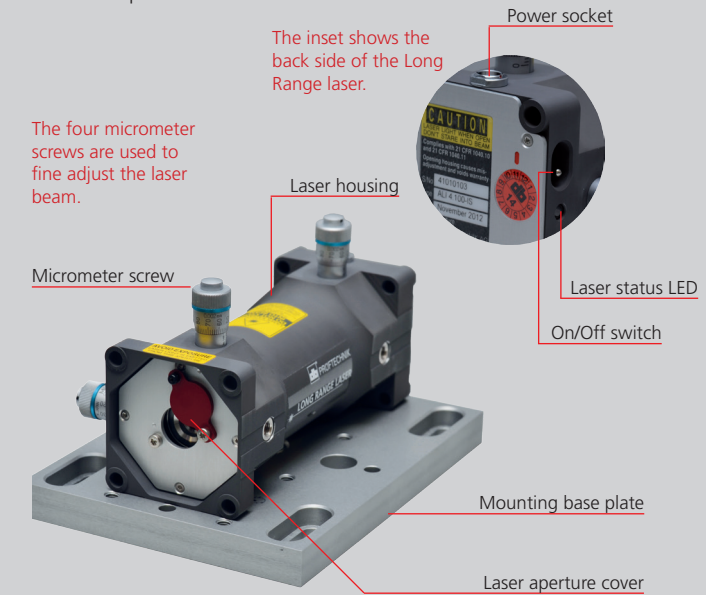

The four micrometer screws are used to fine adjust the laser beam.

The inset shows the back side of the Long Range Laser.

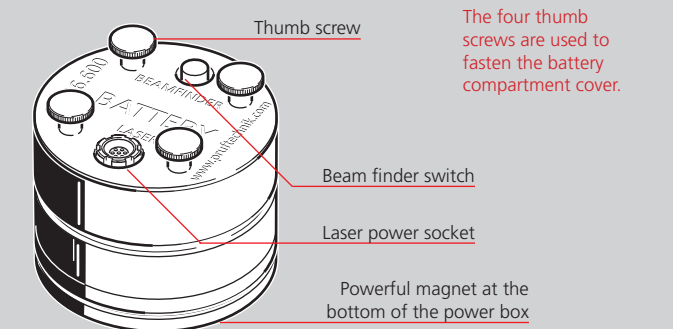

The four thumb screws are used to fasten the battery compartment cover.



Mounting the Long Range Laser

For measurement, the Long Range Laser must be mounted rigidly at the appropriate position. There are two possibilities to carry this out.

- › By use of the threaded holes on the Long Range Laser
- › By use of a mounting plate

Using the threaded holes

The Long Range Laser housing consists four M6 threaded holes positioned on two opposing surfaces of the housing. The Long Range Laser can be affixed to appropriate brackets using its threaded holes.

Mounting plate

The Long Range Laser is attached to the mounting plate using the supplied M6 hex head cap screws. The Long Range Laser must be fixed to the mounting plate through the appropriate holes. These are marked blue in the mounting plate sketch below. Two head cap screws are required when fixing the Long Range Laser lateral to the mounting plate, and four screws when fixed perpendicular to the mounting plate.

Fixing Long Range Laser to mounting plate

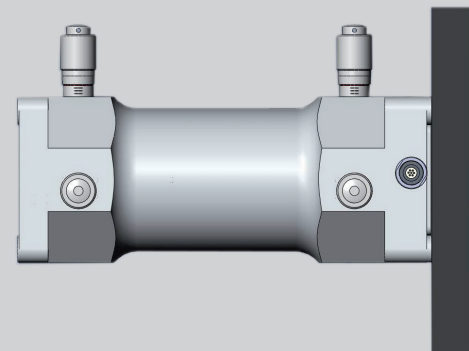

Four head cap screws are used for fixing the Long Range Laser perpendicular to the mounting plate.

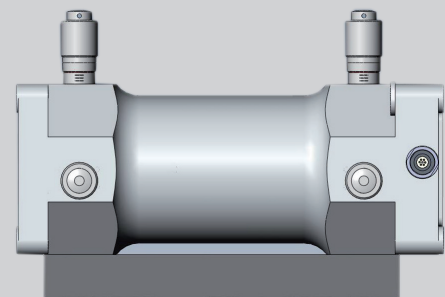

Lateral fixation of the Long Range Laser to the mounting plate requires two head cap screws.

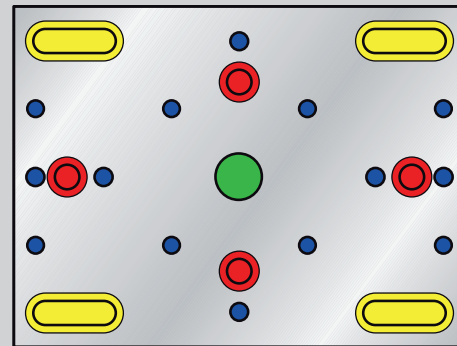

Key to using the mounting plate:

Holes marked red have M6 female threads and are for mounting magnetic foot adapters.

The green hole has a 5/8" female thread and is used to mount tripods.

Yellow openings are used to mount the CENTRALIGN bridge.

Holes marked blue are used to mount the Long Range Laser.

The mounting plate is designed to be mounted an industrial tripod such as LEVALIGN laser tripod ALI 6.956, magnetic foot adapter, the CENTRALIGN bridge ALI 3.231-XXX or the universal pointer bracket bridge ALI 2.715.

Switch Long Range Laser on

- › Connect the power cable to the power sockets on both the power box and the Long Range Laser.
- › Rotate the red laser aperture cover to expose the laser aperture.
- › Use the On/Off switch to turn the Long Range Laser on. The red LED next to the switch starts to blink.

Laser beam adjustment

Beam finder mode

The beam finder mode may be activated to assist in laser beam adjustment. When activated, the emitted laser beam is brighter and easy to spot.

To activate the beam finder mode, press the black beam finder switch on the power box. The red LED next to the Long Range Laser On/Off switch will light steady continuously.

Note

The beam finder mode should be activated only during adjustment of the laser beam. After adjusting the laser beam, turn the beam finder mode off.

Operating principle

A tube with a built-in laser is positioned inside the Long Range Laser housing. The tube is held in its horizontal and vertical positions by micrometer screws and springs. The micrometer screws are further used to accurately adjust the horizontal and vertical position of the laser beam.

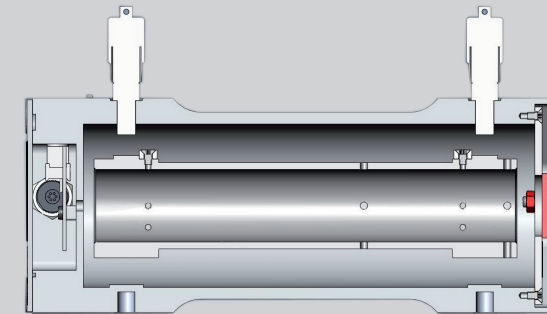

Adjusting the micrometer screws

The sleeve of the micrometer screw has a red line round the outer diameter. It is recommended to initially rotate the thimbles of all the micrometer screws such that the bottom of the thimbles rests on the respective red lines. This sets the laser beam as parallel as possible to the Long Range Laser housing. The position also ensures that the laser beam has maximum room for adjustment (3 mm) in all directions.

The thimble has 50 graduation marks and the increment between the graduation marks is 0.002 mm. Therefore, 1 division equals 0.002 mm, 5 divisions equal 0.01 mm, and a full turn of the thimble represents 0.1 mm.

A correction of 1 mm requires that the thimble be rotated 10 times. Before making any adjustments using the micrometer screws, ensure that the reading on the thimble is noted down. Take the value into consideration during adjustment, especially when it is not zero.

Correcting offset

If both micrometer screws on any one given plane [either horizontal or vertical] are rotated by the same amount and in the same direction, the laser beam experiences an offset equal to rotated value.

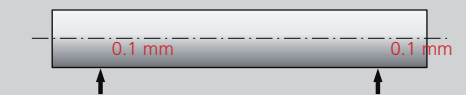

Correcting offset
Values given only as examples

Angular correction

If only a single micrometer screw is rotated regardless of the position, then the laser beam experiences and an angular change.

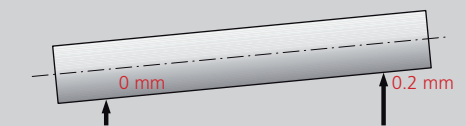

Angular correction

For every complete turn of the thimble [0.1 mm], the laser beam moves by 1 mm per m.

Example:

The laser beam shifts by 40 mm from an angular correction of 0.1 mm over a distance of 40 m.

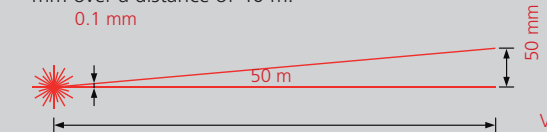

Values given only as examples