

VIBRONET[®] Signalmaster

Online Condition Monitoring
for industrial plants and dis-
tributed operating facilities

Catalog



PRÜFTECHNIK
Condition Monitoring
info@pruftechnik.com

Edition: 12-2011
Order no.: LIT 58.700.DE

Legal notices

Both this catalog and the product it describes are copyrighted. All rights belong to the publisher. The catalog may not be copied, reproduced, translated or made accessible to a third party in any form, neither in its entirety nor as an excerpt.

No liability may be claimed against the publisher regarding the product described in this catalog. The publisher assumes no liability for accuracy of the catalog contents. Furthermore, under no circumstances may the publisher be held liable for direct or indirect damage of any kind resulting from use of the product or the catalog, even if the publisher has expressly indicated the potential for occurrence of such damage.

The publisher assumes no liability for any product defects. This warranty and liability limitation applies to all distributors and sales partners as well.

The trademarks mentioned in this catalog are generally noted as such and are the property of their owners. Lack of such designation does not imply, however, that names are not protected by trademark laws.

©2011 PRÜFTECHNIK Condition Monitoring; all rights reserved

Contents

Chapter 1

VIBRONET Signalmaster System

VIBRONET Signalmaster - Online Condition Monitoring for up to 162 meas. locations	6
---	---

Art.Nr.	Produktbezeichnung	Seite
VIB 5.890-1 :	VIBRONET Signalmaster standard package for 9-channel field multiplexers and one string line	8
VIB 5.890-3 :	VIBRONET Signalmaster standard package for 9-channel field multiplexers and three string lines.....	9
VIB 5.802 :	VIBRONET Signalmaster basic unit.....	10
VIB 5.962 :	Power supply for VIBRONET Signalmaster, 5 VDC	13
VIB 5.963 :	Power supply for VIBRONET Signalmaster, 12 VDC	13
VIB 5.956-X :	System bus cable for VIBRONET Signalmaster with X connectors.....	14
VIB 5.815-1 :	Shock pulse module with one Current Linedrive input for VIBRONET Signalmaster	15
VIB 5.815-3 :	Shock pulse module with three Current Linedrive inputs for VIBRONET Signalmaster.....	15
VIB 8.310 :	Temperature module for VIBRONET field multiplexer	17
VIB 8.312 :	Process parameters module (current/ voltage) for VIBRONET field multiplexer	17
VIB 8.313 :	RPM module for VIBRONET field multiplexer	17
VIB 8.310 EX :	Temperature module for VIBRONET field multiplexer, intrinsically safe.....	17
VIB 8.313 EX :	RPM module for VIBRONET field multiplexer, intrinsically safe.....	17
VIB 8.314 EX :	Vibration module for VIBRONET field multiplexer, intrinsically safe.....	17
VIB 8.306 :	Field multiplexer with threaded fitting M12 for VIBRONET Signalmaster	18
VIB 8.306 S :	Field multiplexer with threaded fitting M20 for VIBRONET Signalmaster	18
VIB 8.306 V :	Field multiplexer with stainless steel housing for VIBRONET Signalmaster	18
VIB 8.306 EX :	Field multiplexer with threaded fitting M12 for VIBRONET Signalmaster, intrinsically safe	19
VIB 8.306 XS :	Field multiplexer with threaded fitting M20 for VIBRONET Signalmaster, intrinsically safe	19
VIB 8.306 XV :	Field multiplexer with stainless steel housing for VIBRONET Signalmaster, intrinsically safe.....	19
VIB 3.550 :	Limiting device for Current LineDrive accelerometers with intrinsic safety	19
VIB 5.917 :	Output module with two SPDT relays for VIBRONET Signalmaster	20
VIB 5.973 :	Terminal with voltage limitation, 5 Volt	21

Chapter 2

VIBRONET Signalmaster accessories

VIB 5.818-N :	16-channel multiplexers for ICP-type or Current LineDrive accelerometers	24
VIB 5.818-NEV :	16-channel multiplexers for event recording	24
VIB 5.819-4x4 :	16-channel multiplexers with 4x4 synchronous inputs	24
VIB 5.819-8x2 :	16-channel multiplexers with 8x2 synchronous inputs.....	24
VIB 5.816 :	Connection module for Current LineDrive accelerometers.....	27
VIB 5.812-ICP :	Connection module for ICP-type accelerometers.....	28
VIB 5.910 :	Add-on module for digital output	29
VIB 5.959 :	Industrial 5-Port ethernet switch for VIBRONET Signalmaster.....	32
VIB 5.955-X :	Patch cable	33
VIB 5.957-2 :	Crossover ethernet cable, 2 m.....	33
VIB 5.957-5 :	Crossover ethernet cable, 5 m.....	33
VIB 5.964-1,5 :	Power supply for VIBRONET Signalmaster, 24 V / 1,5 A	34
VIB 5.964-2,5 :	Power supply for VIBRONET Signalmaster, 24 V / 2,5 A	34
VIB 5.964-5 :	Power supply for VIBRONET Signalmaster, 24 V / 5 A	34
VIB 5.920-MOD :	Slave connection module for Modbus Plus fieldbus system.....	35
VIB 5.970-M :	Terminal with high-voltage fuse and transient protection for the signal cable	36
VIB 5.970-P12 :	Terminal with high-voltage fuse and transient protection for the 12VDC power supply	36
VIB 5.970-P24 :	Terminal with high-voltage fuse and transient protection for the 24VDC power supply	36
VIB 5.970-P250 :	Terminal with high-voltage fuse and transient protection for the 250VAC power supply.....	36
VIB 5.972 :	Terminal for conversion of 20mA signals into voltage signals.....	37
VIB 5.974-T2 :	Terminal with voltage divider 1 / 2.....	38
VIB 5.974-T3 :	Terminal with voltage divider 1 / 3.....	38
VIB 5.974-T4 :	Terminal with voltage divider 1 / 4.....	38
VIB 5.975 :	Connection terminal for potential-free contact signals	39
VIB 8.957 :	OMNITREND for VIBRONET Signalmaster Standard, software package.....	40
VIB 5.883 :	VIBRONET Signalmaster device driver for OMNITREND	40
VIB 8.957-P :	PC licence for VIBRONET Signalmaster	40
Installation examples.....	41	

Index

Index by order number	47
-----------------------------	----









Chapter 1

VIBRONET Signalmaster System



VIBRONET Signalmaster - Online Condition Monitoring for up to 162 meas. locations

1
2

-  **Vibration**
-  **Bearing condition**
-  **Temperature**
-  **RPM**
-  **Process parameters**
-  **FFT spectrum**
-  **Envelope**
-  **Time waveform**
-  **Intrinsic safety (option)**

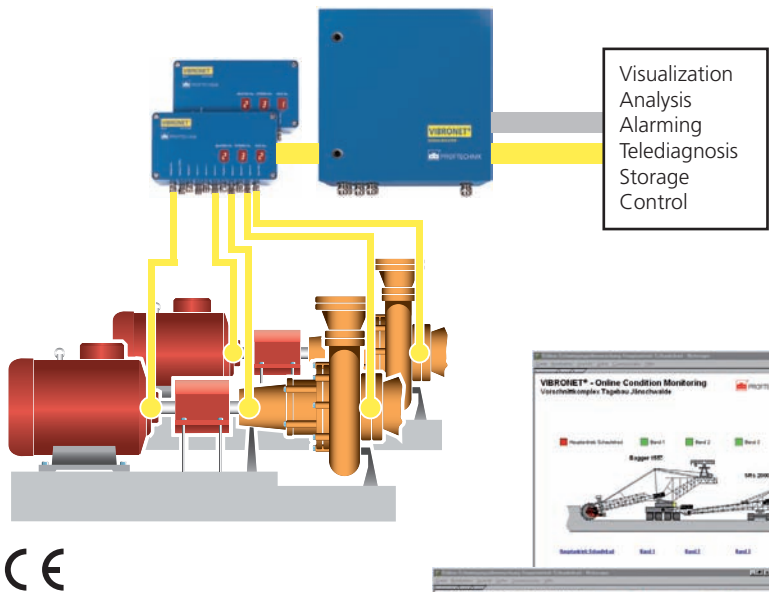

The VIBRONET Signalmaster is an online condition monitoring and diagnostic system for machines in industrial plants and distributed operating facilities. The system can be expanded by a series of program modules that are specific to the application:

- Band analysis module for the automatic evaluation of complex vibration processes in rolling bearings, gears or special machines.
- Cepstrum analysis
- Orbit analysis
- Data server for the automatic or event-controlled read out of data and for transferring them to higher systems

Software

All functions are provided by Java applets. The following range of functions is included in the standard version:

- Standardized graphic user interface
- List of all locations in the alarm state
- List of all locations in the warning state
- List of all locations with sensor error
- Trend history for each aggregate showing all essential events (with OMNITREND PC software only)
- Trend export of the data to the PC
- Online diagnosis: Velocity, acceleration and envelope spectrums, as well as time records for all acceleration transducers.
- Alarm spectrum: The system measures and stores alarm signals (e.g. alarm spectra) automatically if alarm or warning limits are exceeded for the measuring location concerned.

Option

- Condition overview indicated on the machine diagram by a change of colors (red, yellow, green)
- Online trend: General overview of the characteristic values and their current trend.
- Online meter: Displays the current overall values; change of colors when threshold values are exceeded.

Automation

The VIBRONET Signalmaster is not only a monitoring system. Due to its programming capability, it can operate as an automated system that is also in a position to control process and measurement parameters and performs detailed analyses on complex systems (optional).

The VIBRONET Signalmaster can be programmed so that it only indicates the possible initial indications of specific damage. Instead of the message "Vibration monitoring registers alarm", the VIBRONET Signalmaster can send "Damage beginning on 2nd. gear stage mixer gear 5, material preparation" as an SMS to a cell phone or to a fault reporting system in the control room.

External connection

VIBRONET Signalmaster operates as a web server. Therefore, the standard data interface is the TCP/IP Internet protocol. Thus, the VIBRONET Signalmaster can be integrated directly as another computer in an existing net-

work. Data can then be accessed from any point in the network or, even from outside the network via a router. Data exchange on site is possible via an Ethernet patch cable (TCP/IP) or a serial cable connection via the RS232 interface (PPP protocol).

Further possibilities for communication include:

- GPRS router
- WLAN
- Satellite communication
- Fieldbus connection
- DDE connection to the PLC

Configuration

The system is pre-configured according to the requirements of the machines to be monitored. This includes the programming, creating HTML pages as the user interface and the initial configuration of the warning and alarm values.

VIBRONET Signalmaster: Functionality and communication

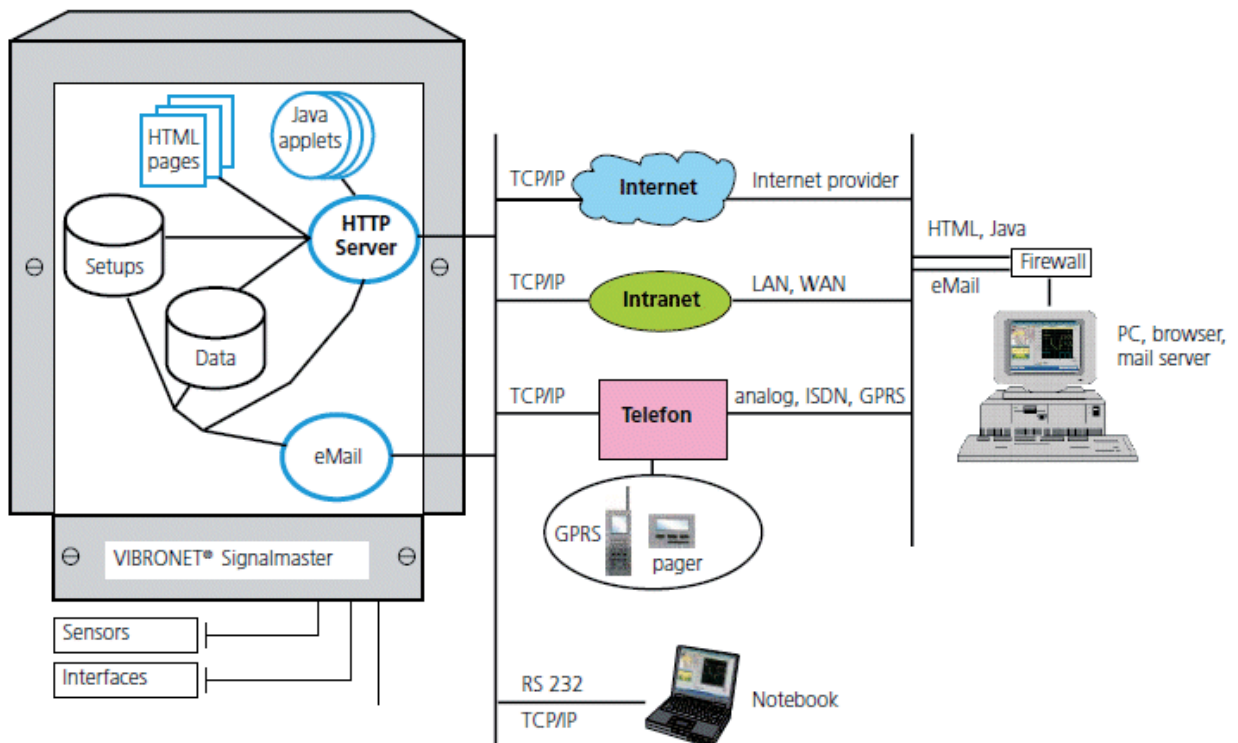

VIB 5.890-1 : VIBRONET Signalmaster standard package for 9-channel field multiplexers and one string line

1

2

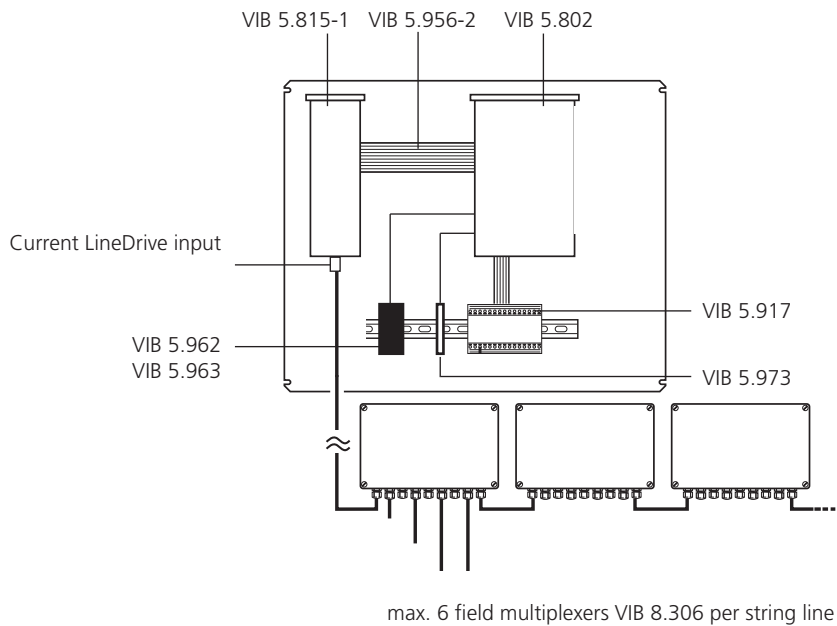

This package provides up to 54 measurement channels to monitor standard machinery (i.e. motor, pump, blower,...). Up to six field multiplexers (VIB 8.306) with nine transducers can be connected in a string. All components are mounted and wired in a robust cabinet.

Field multiplexer with 9 channels

- Connection via module VIB 5.815-1 (1 current LineDrive input)
- Up to 6 multiplexers with up to 54 transducers can be connected to the basic unit.
- Long cabling between multiplexers and the VIBRONET Signalmaster basic unit.

Scope of delivery

VIB 5.802	VIBRONET Signalmaster basic unit
VIB 5.962	Power supply, 5V
VIB 5.963	Power supply, 12V
VIB 5.956-2	Systembus cable with two connectors
VIB 5.815-1	Shock pulse module for one string line
VIB 5.917	Output module with two SPDT relays
VIB 5.973	Terminal with voltage limitation 5V, 5 pcs.
VIB 9.520.G	Installation instructions
LIT 01.800	CD ROM, Condition Monitoring catalogs, brochures, magazines
Not shown	
055060160	Cabinet
003370073	Patch cable, 1 m

VIB 5.890-3 : VIBRONET Signalmaster standard package for 9-channel field multiplexers and three string lines

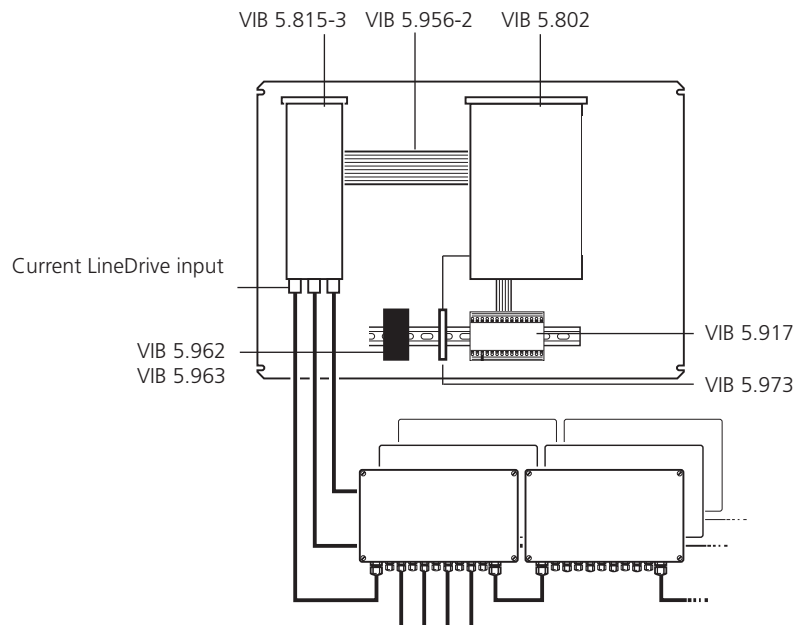

max. 6 field multiplexers VIB 8.306 per string line

This package provides up to 162 measurement channels to monitor standard machinery (i.e. motor, pump, blower,...). Up to six field multiplexers (VIB 8.306) with nine transducers can be connected in a string. All components are mounted and wired in a robust cabinet.

Field multiplexer with 9 channels

- Connection via module VIB 5.815-3 (3 current Line-Drive inputs)
- Up to 3x6 multiplexers with up to 162 transducers can be connected to the basic unit.
- Long cabling between multiplexers and the VIBRONET Signalmaster basic unit.

Scope of delivery

VIB 5.802	VIBRONET Signalmaster basic unit
VIB 5.962	Power supply, 5V
VIB 5.963	Power supply, 12V
VIB 5.956-2	Systembus cable with two connectors
VIB 5.815-3	Shock pulse module for three string lines
VIB 5.917	Output module with two SPDT relays
VIB 5.973	Terminal with voltage limitation 5V, 5 pcs.
VIB 9.520.G	Installation instructions
LIT 01.800	CD ROM, Condition Monitoring catalogs, brochures, magazines
Not shown	
055060160	Cabinet
003370073	Patch cable, 1 m

VIB 5.802 : VIBRONET Signalmaster basic unit

1

2

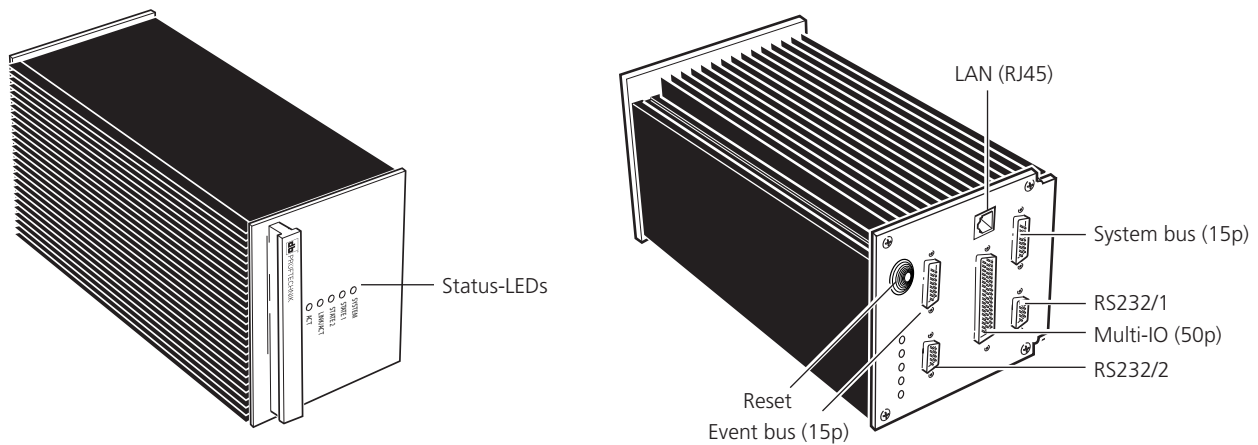

Application

Online Condition Monitoring and Diagnosis of rotating machinery in industrial plants and distributed operating facilities.

Short description

- The VIBRONET Signalmaster basic unit combines the features of intelligent data loggers, transient recorders, classifying instruments, programmable control units and recording systems.
- Sensors (e.g. for temperature, pressure, flow, power, RPM, torque, acceleration, etc.) can be directly connected.
- Digital outputs are available for controlling actors.
- Analog outputs are provided by add-on modules.
- External data devices can be connected via standard interfaces such as RS-232 or Ethernet.
- Several basic units can be networked either with one another via Ethernet or with other devices.

- TCP/IP, Web server (HTTP and FTP) and Email server.
- Operation, visualization and evaluation can be performed on the basic unit.
- TCP/IP communication via Inter-/ Intranet, LAN, WLAN, phone, mobile phone and RS232.
- The basic unit is connected to field bus systems and process control systems via appropriately configured connection modules.
- The real time multi-tasking operating system coordinates the interplay of application programs, data processing, data storage, communication and system monitoring.
- The user can comfortably set up and optimize the measurement parameters and limiting values with the OMNITREND PC software.
- Suitable for autonomous use in an industrial environment.
- Tested for tropical climate resistance and electromagnetic compatibility.

Technical data

PARAMETER		VIB 5.802
Interfaces	Meas. channels, analog	6 differential inputs (3 of them synchronous)
	Meas. channels, digital	RPM / Counter: 2 x TTL...30 V Keyphaser: ± 30 V AC and DC
	Input channels, digital	4 x, TTL...30 V
	Output channels, digital	8 x, 5 V, 5 mA
	Ethernet	1, data rate: 100 Mbit
	Serial - RS 232	2, data rate: 115,2 kBit
	FET switching output	12 V DC, 1 A, switchable
	Expanded no. of channels	External multiplexer for analog and digital outputs
Measurement	Meas. range, analog	± 10 V, ± 1 V, ± 100 mV, ± 10 mV
	Dynamic Range / Resolution	96 dB / 16 bit ADC
	Accuracy, analog input	0.05% of full scale
	Common mode rejection	> 115 dB at an amplification of 60 dB
	Temperature coefficient, analog input	20 ppm / K
	Input protection	Differential input: ± 12 V Digital input: + 30 V
	SW-Downsampling	4.8 / 2.4 / 1.2 / 0.6 / 0.3 / 0.15 kHz
	Phase error, synchronous analog inputs	< 0,05 %
	Crosstalk between analog inputs	< -100 dB
	Dynamic amplitude errors	< -0.1 dB (up to 50% of the max. signal frequency) < - 0.5 dB (up to 75% of the max. signal frequency) < -1.0 dB (up to 80% of the max. signal frequency) < - 3.0 dB (up to 100% of the max. signal frequency)
	Counter frequency	< 10 kHz
	Signal coupling	DC (AC/DC on the differential synchr. inputs)
	Sampling rate, analog inputs	153.6 / 76.8 / 38.4 / 19.2 / 9.6 kHz
	Frequency range	0...50 Hz to 0...50 kHz, sub-divided into 11 areas
	Frequency resolution	400, 800, 1600, 3200, 6400, 12800 lines
	Anti-aliasing	Dynamic adaptation
	Envelope	Digital input filter, selectable
	Measurement functions	Time waveform, spectrum, integration of the spectrum, envelope, orbit, Overall values: shock pulse, acceleration (RMS), vibration velocity (peak, RMS)
Operation modes	Frequency band analysis, transient memory, online classification, trending	
General parameters	Power supply	5.05V / 1.5A max. and 12V / 1.2A max.
	Memory	RAM: 128 MB / Flash: 1000 MB
	Temperature range, operation	- 20°C ... +60°C
	Humidity	10% to 100%, dew permitted
	Mechanical load	Shock:30 g / constant vibration: 2 g (10-150 Hz)
	Protection class	IP 66 (EN 60529) / NEMA 4
	Dimensions	approx. 260 x 130 x 150 mm (L x W x H)
	Total weight	approx. 1.5 kg

Connection plan for VIB 5.802

1

RS 232 (Sub-D 9)

Sub-D no.	RS232-1	RS232 -2
1	-	-
2	TxD	TxD
3	RxD	RxD
4	-	-
5	Gnd	Gnd
6	-	-
7	-	-
8	-	RTS
9	-	-

Eventbus (Sub-D 15)

Sub-D no.	Channel
1	Hi3 (AD3)
2	Lo3 (AD3)
3	AG
4	CLK-AD3
5	12V
6	PG
7	
8	
9	RST-AD3
10	
11	
12	
13	
14	
15	

Systembus (Sub-D 15)

Sub-D no.	Channel
1	Hi3 (AD3)
2	Lo3 (AD3)
3	AG
4	MUX-CLK (OUT12)
5	12V
6	PG
7	SDM1 (OUT9)
8	SDM2 (OUT10)
9	SDM3 (OUT11)
10	Hi4 (AD1)
11	Lo4 (AD1)
12	Hi1 (AD1)
13	Lo1 (AD1)
14	Hi2 (AD2)
15	Lo2 (AD2)

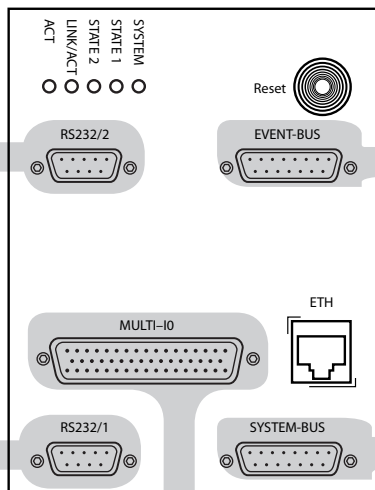

Multi functional interface (Sub-D 50)

Sub-D no.	Channel	Sub-D no.	Channel	Sub-D no.	Channel
1	LAN:Tx+	18	LAN:Rx+	34	PE
2	LAN:Tx-	19	LAN:Rx-	35	KP/DC
3	12V Switch	20	OUT8	36	12V
4	5V	21	PG	37	PG
5	IN1	22	PG	38	IN3
6	IN2	23	PG	39	IN4
7	OUT1	24	PG	40	OUT3
8	OUT2	25	PG	41	OUT4
9	P1	26	PG	42	P2
10	KP/AC	27	OUT6	43	SYNC
11	OUT5	28	Lo1 (AD1)	44	OUT7
12	Hi1 (AD1)	29	Lo2 (AD2)	45	AG
13	Hi2 (AD2)	30	Lo3 (AD3)	46	AG
14	Hi3 (AD3)	31	Lo4 (AD1)	47	AG
15	Hi4 (AD1)	32	Lo5 (AD1)	48	AG
16	Hi5 (AD1)	33	Lo6 (AD1)	49	AG
17	Hi6 (AD1)			50	AG

- 12V Voltage supply for Event bus and System bus
- PG Ground potential for power supply and digital signal line
- AG Ground potential for analog signal line
- MUX-CLK Multiplexer control line
- SDM Address bus
- HiLo Analog signal line
- CLK, RST Event multiplexer control line

Power supply

- 5V 5.05V / 1.5A max.
- 12V 12V / 1.2A max.
- Power input depends on the attached accessory equipment.
- PG Ground potential for power supply and digital signal line
- AG Ground potential for analog signal line

Digital interfaces

- IN's**
- IN1-IN4 TTL - 30V
- P1, P2 TTL - 30 V
- KP/AC $U_{bias} \pm 30V, dU_{min} 0,5V, dT_{min} 100\mu s, dU/dT_{min} 1V/ms$
- KP/DC $U_{bias} \pm 30V, dU_{min} 0,5V, dT_{min} 100\mu s$
- SYNC TTL-30V

OUT's

- OUT1-OUT8 5V/ 5mA Sink and Source
- 12VSwitch 12V/ 1,0A

Analog interfaces

- HiLo1-HiLo6 IN: $\pm 10V; \pm 1V; \pm 0,1V; \pm 0,01V$

Communication

- Ethernet-LAN, 100 Mbit

Power supply for VIBRONET Signalmaster

VIB 5.962 : Power supply for VIBRONET Signalmaster, 5 VDC

VIB 5.963 : Power supply for VIBRONET Signalmaster, 12 VDC

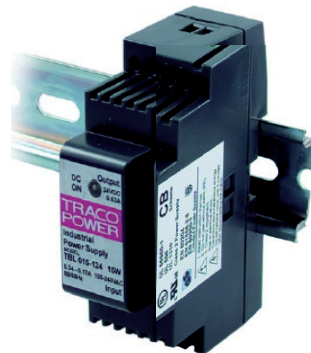

Application

Power supply for the VIBRONET Signalmaster basic unit.

Technical data

PARAMETER		VIB 5.962	VIB 5.963
Input	Voltage, nominal	100 - 240 VAC	
	AC range	85 - 264 VAC (Power reduction of 5% / V when operating at an input voltage below 90 VAC)	
	Mains frequency	47...63 Hz	
Output	Voltage, nominal	5 VDC	12 VDC
	Power	< 12 W	< 15 W
	Current	< 2,4 A	< 1,25 A
	Setting range	5.0 - 5.2 VDC	12 - 16 VDC
General parameters	Temperature range, Operation	-25°C ... +70°C max.	
	Temperature range, Storage	-40°C ... +85°C max.	
	Power reduction	2.5% / K above 60°C	
	Humidity	5 - 95 % (non-condensing)	
	Protection class	Class II (IEC/EN 61140)	
	Environmental protection	IP 20	
	Housing material	Plastic FR2010-110C (UL 94 V-O-class)	
	Mounting	35 mm DIN rail (snapable)	
	Connection terminal	Screw-type, cross section 0.5-1.5 mm ²	
	Dimensions	approx. 60 x 26 x 90 mm (LxWxH)	

VIB 5.956-X : System bus cable for VIBRONET Signalmaster with X connectors

1
2

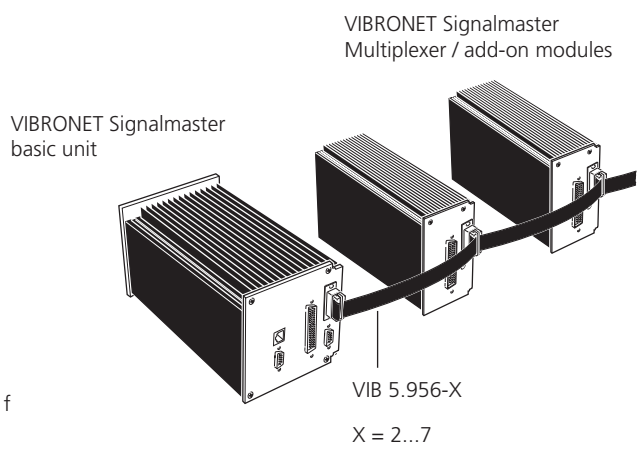
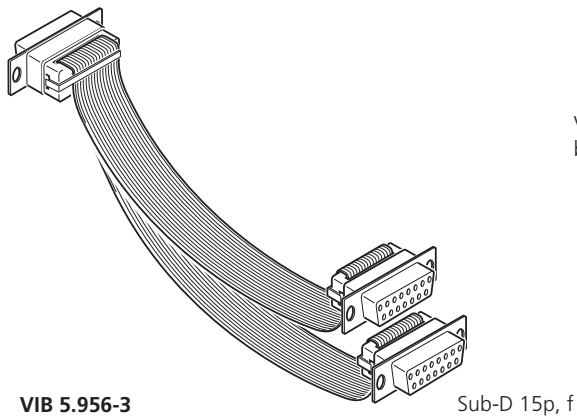

Application

Connection of the 16-channel multiplexers and add-on modules to the VIBRONET Signalmaster for the transmission of analog and digital measurement and control signals.

Description

The system bus cable is a 15-wire ribbon cable. At a distance of about 0.5 meter 15-pole Sub-D connectors are attached for connecting system components.

Note

The expansion of an existing system bus requires a system bus cable with the relevant number of connectors.

Pin allocation: System bus cable

PIN	Function
1	Hi3
2	Lo3
3	AG
4	MUX-CLK
5	12 V
6	PG
7	SDM1
8	SDM2
9	SDM3
10	AG
11	AG
12	Hi1
13	Lo1
14	Hi2
15	Lo2

12VDC/15mA 12V DC current supply
 PG Reference zero for the 12V supply
 AG Analog reference zero
 MUX-CLK Impulse for channel switching
 SDM A-wire for triggering
 HiLo Analog signal line

Shock pulse modules for VIBRONET Signalmaster

VIB 5.815-1 : Shock pulse module with one Current Linedrive input for VIBRONET Signalmaster

VIB 5.815-3 : Shock pulse module with three Current Linedrive inputs for VIBRONET Signalmaster

VIB 5.815-1

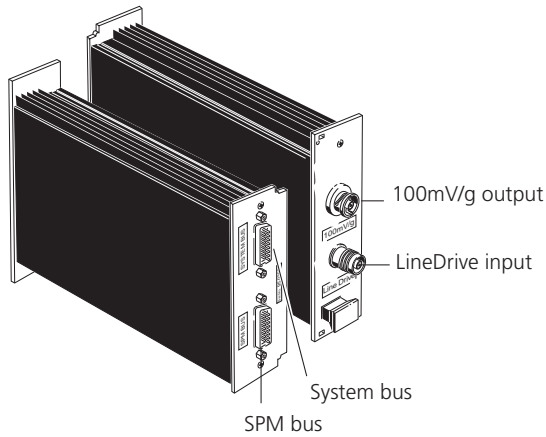

VIB 5.815-3

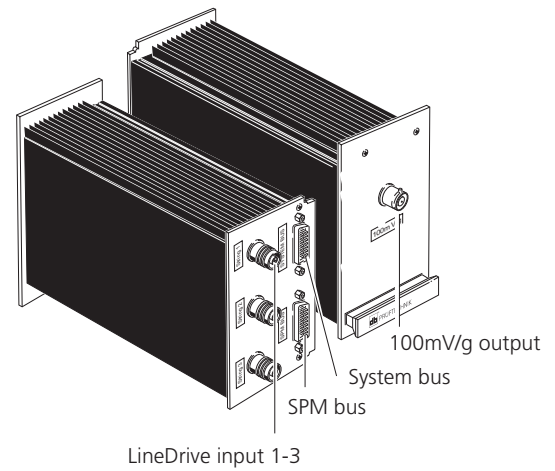

Application

These modules are used for connecting 9-channel field multiplexers (VIB 8.306) or transducers with current linedrive output to the VIBRONET Signalmaster basic unit. In conjunction with 16-channel multiplexers (VIB 5.818 / VIB 5.819), the modules can be used for shock pulse measurements

Function

The current linedrive signals from the transducer/ multiplexer are converted into a voltage signal for the VIBRONET Signalmaster by a current mirror circuit integrated in the module.

The module has a buffered analog output (100 mV/g), at which the transducer signal can be displayed using a suitable measuring device.

The module obtains the control signals for further channel switching via the system bus from the VIBRONET Signalmaster.

Technical data

PARAMETER		VIB 5.815-1	VIB 5.815-3
Interfaces	Inputs	1x SPM bus, Sub-D-15 1x TNC, Current LineDrive	1x SPM bus, Sub-D-15 3x TNC, Current LineDrive
	Electrically isolated	No	
	Control input	System bus	
	Outputs	1x System bus, Sub-D-15 1x BNC, 100mV/g, referred to 1µA sensor	
	Connections	1x 6 field multiplexers with up to 54 channels, or 1x 16-channel multiplexer	3x 6 field multiplexers with up to 162 channels, or 1x 16-channel multiplexer
Electrical	Power supply	12 VDC from system bus	
	Current consumption	< 250 mA	
	Detection of short circuit	with DC measurement, > 5.5V	
	Detection of open circuit	with DC measurement, < 500 mV	
	Current limitation (sensor short circuit)	yes	
General	Temperature range, operation	0°C ... +50°C	
	Housing material	Aluminium	
	Mounting (option)	Adapter for top hat rail (NS35/15)	
	Dimensions	approx. 130 x 240 x 35 mm (HxWxD)	approx. 130 x 240 x 70 mm (HxWxD)

Application example 1:

Shock pulse measurement with Current LineDrive transducer and 16-channel multiplexer

1
2

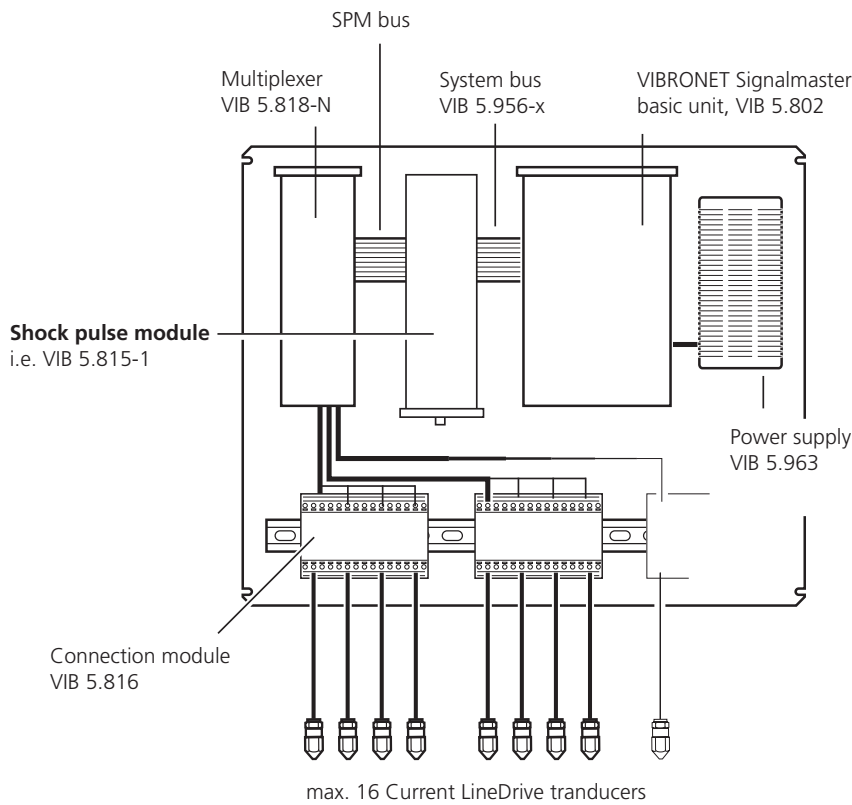

Application example 2:

Connection of 9-channel field multiplexers

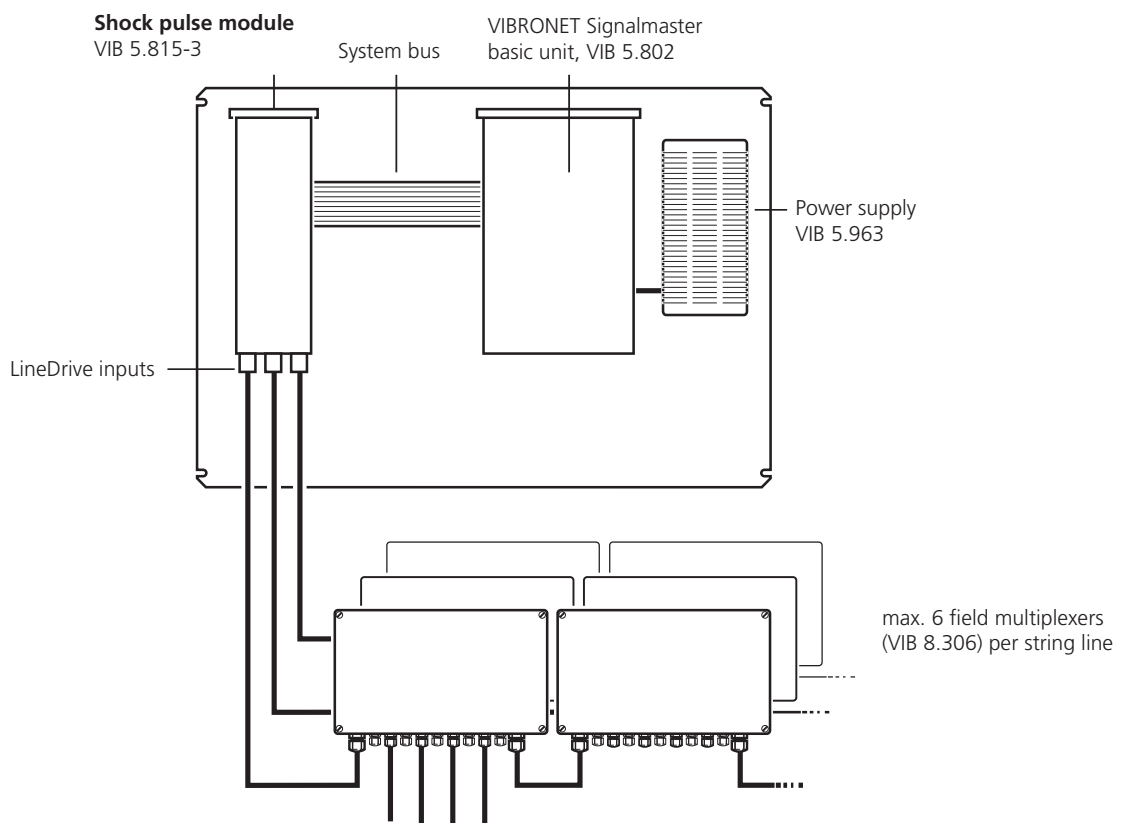

Connection modules for VIBRONET field multiplexers

VIB 8.310 :	Temperature module for VIBRONET field multiplexer
VIB 8.312 :	Process parameters module (current/ voltage) for VIBRONET field multiplexer
VIB 8.313 :	RPM module for VIBRONET field multiplexer
VIB 8.310 EX :	Temperature module for VIBRONET field multiplexer, intrinsically safe
VIB 8.313 EX :	RPM module for VIBRONET field multiplexer, intrinsically safe
VIB 8.314 EX :	Vibration module for VIBRONET field multiplexer, intrinsically safe

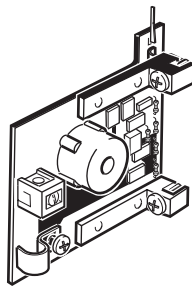

VIB 8.310

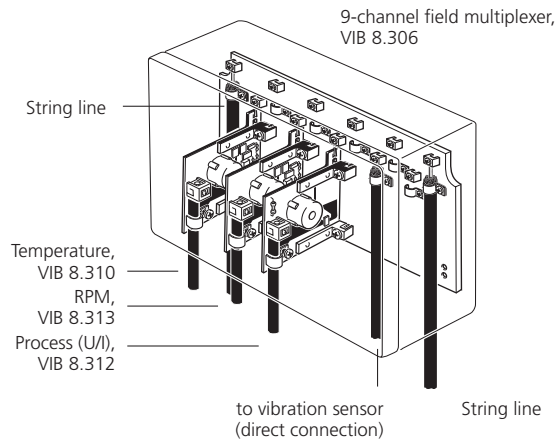

CE 0044

Application

These modules are required for the connection of the appropriate sensor cable in the VIBRONET field multiplexer.

Description

The VIB 8.310 module converts the resistance value of the Pt100 temperature probe (VIB 6.610) into a digital current signal.

The VIB 8.312 module allows connection to measurement instruments with a standard current or standard voltage output (4-20 mA, 0-10V). This allows monitoring of process parameters, e.g. pressure, flow rate, etc..

The VIB 8.313 module is used to connect a RPM sensor to the multiplexer.

CLD-type accelerometers are connected directly to the multiplexer board. In hazardous areas the connection module VIB 8.314 EX is required for this type of sensor.

Notes on intrinsic safety

The details in the examination certificate of the VIBRONET field multiplexer (type: VIB ..- 8.3 EX) TÜV 02 ATEX 1962 must be considered.

Additionally the following documents must be observed:

- European installation instructions (EN 60079-14:1997, EN 61241-14:2004)
- Installation notes for hazardous areas annexed in the sensor catalog LIT 01.700.EN.
- VIBRONET installation instructions VIB 9.520.G

Abbreviation

CLD: Current Line Drive

Technical data

PARAMETER		VIB 8.310	VIB 8.312	VIB 8.313	VIB 8.314 EX
Electrical	Input	Pt100 temperature probe	Current / Voltage	Inductive proximity sensor	CLD-type accelerometer
	Output	Digitalized current signal			
	Sensitivity	0,385 Ohm/°C	--	2 mA	--
	Current output to sensor	< 2 mA	--	< 4 mA	--
	Voltage output to sensor	< 1 V	< 2.2 V (at connector, current module) 10 kOhm (Input resistance, voltage module)	< 8 V	--
	Balancing resistor	--			100 Ω
General	Temperature range, operation	-20°C ...+80°C			-20°C ...+70°C
	Dimensions	46 x 50 x 2 mm			

Field multiplexers for VIBRONET Signalmaster

1
2

- VIB 8.306 : Field multiplexer with threaded fitting M12 for VIBRONET Signalmaster
- VIB 8.306 S : Field multiplexer with threaded fitting M20 for VIBRONET Signalmaster
- VIB 8.306 V : Field multiplexer with stainless steel housing for VIBRONET Signalmaster

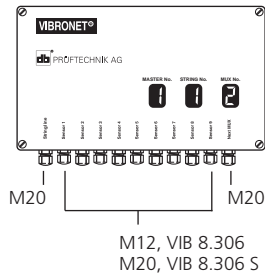

VIB 8.306 V

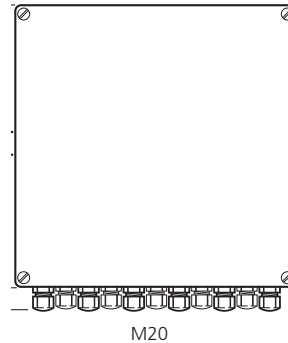

Application

These field multiplexers are used as channel switch selectors in the VIBRONET Signalmaster online CMS. The industrial-proofed field multiplexer for up to nine measuring channels reduces the number of signal lines to one single connection and, thus, saves installation costs. The channel is switched automatically by the online CMS.

The stainless steel housing enables the multiplexer to be installed in chemically aggressive environments (especially basic).

Modularity

Up to six multiplexers can be connected in series to form a single bus string with up to 54 measurement channels. Up to three bus strings can be connected to the VIBRONET Signalmaster.

Connections

Sensor cables for vibration measurements are directly connected to the multiplexer board. For the connection of RPM, temperature, current and voltage sensors special multiplexer modules are required.

Accessories

- VIB 7.590 Metric fitting M16, 5x
- VIB 7.592 Metric fitting M20, 2x
- VIB 8.310 Temperature module
- VIB 8.312 Process parameters module (current / voltage)
- VIB 8.313 RPM module

Technical data

PARAMETER		VIB 8.306	VIB 8.306 S	VIB 8.306 V
General	Housing material	Cast aluminum housing, powder coated		Stainless steel (VA)
	Inputs / Outputs	9 sensor inputs, 1 string input, 1 string output		
	Env. protection	IP 65		IP 66
	Temperature range	-40C° ... +80°C		
	Clamping range M12	3.0 ... 6.5 mm		--
	-, M20	7.0 ... 12.0 mm		
	Dimensions LxWxD	224 x 120 x 98 mm		255 x 255 x 130 mm
	Weight	approx. 3 kg		approx. 5 kg
Electrical	Power supply	Approx. 10 V from VIBRONET Signalmaster 'string' output		
	Current consumption	In µA range		
	Interference protect.	Inputs and outputs protected by suppressor diodes		

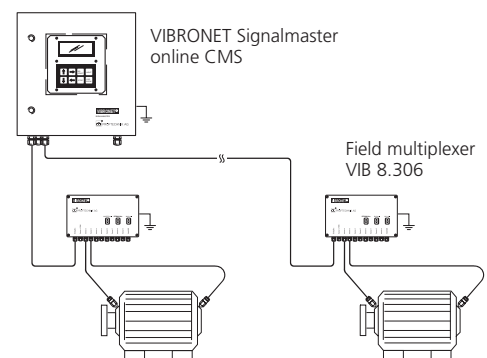

Field multiplexers with intrinsic safety for VIBRONET Signalmaster

VIB 8.306 EX : Field multiplexer with threaded fitting M12 for VIBRONET Signalmaster, intrinsically safe

VIB 8.306 XS : Field multiplexer with threaded fitting M20 for VIBRONET Signalmaster, intrinsically safe

VIB 8.306 XV : Field multiplexer with stainless steel housing for VIBRONET Signalmaster, intrinsically safe

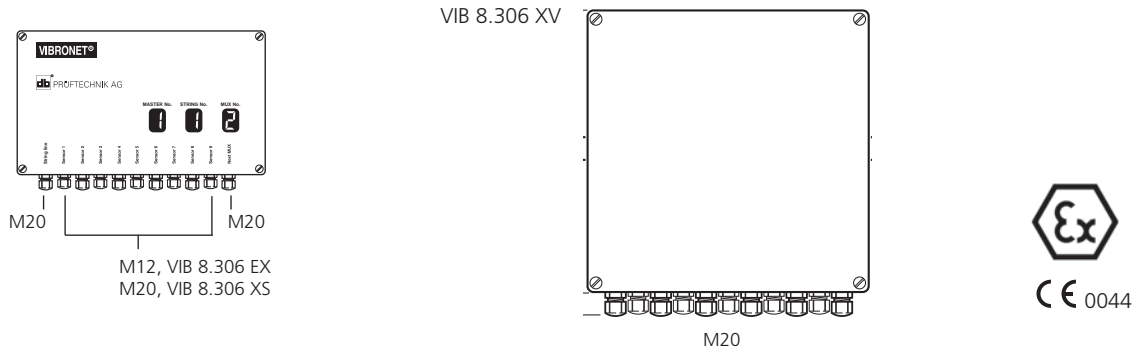

Application

These field multiplexers can be installed in hazardous areas and are used as channel switch selectors in the VIBRONET Signalmaster online CMS. The industrial-proofed field multiplexer for up to nine measuring channels reduces the number of signal lines to one single connection and, thus, saves installation costs. The channel is switched automatically by the online CMS.

The stainless steel housing enables the multiplexer also to be installed in chemically aggressive environments (especially basic).

Modularity and connections

Four multiplexers can be connected in series to form a single bus string with up to 36 measurement channels. Up to three bus strings can be connected to the VIBRONET Signalmaster with a total of 108 measurement channels. All sensor cables are connected via appropriate connection modules in the multiplexer.

Notes on intrinsic safety

The details in the examination certificate of the VIBRONET field multiplexer (type: VIB ..- 8.3 EX) TÜV 02 ATEX 1962 must be considered.

Additionally the following documents must be observed:

- European installation instructions (EN 60079-14:1997, EN 61241-14:2004)
- Installation notes for hazardous areas annexed in the sensor catalog LIT 01.700.EN.
- VIBRONET installation instructions VIB 9.520.G

Accessories

- VIB 7.590 Metric fitting M16, 5x
- VIB 7.592 Metric fitting M20, 2x
- VIB 8.310 EX Temperature module, intr. safe
- VIB 8.313 EX RPM module, intr. safe
- VIB 8.314 EX Vibration module, intr. safe
- VIB 3.550 Limiting device for Current LineDrive accelerometers with intrinsic safety

Technical data

PARAMETER		VIB 8.306 EX	VIB 8.306 XS	VIB 8.306 XV
General	Housing material	Cast aluminum housing, powder coated		Stainless steel (VA)
	Inputs / Outputs	9 sensor inputs, 1 string input, 1 string output		
	Env. protection	IP 65		
	Temperature range	-20C° ...+70°C		
	Clamping range M12	3.0 ... 6.5 mm		--
	-, M20	7.0 ... 12.0 mm		
	Dimensions LxWxD	224 x 120 x 98 mm		255 x 255 x 130 mm
Weight	approx. 3 kg		approx. 5 kg	
Electrical	Power supply	Approx. 10V from VIBRONET Signalmaster 'string' output		
	Current consumption	In µA range		
	Interference protect.	Inputs and outputs protected by suppressor diodes		
EX	Marking	II 2 G EEx ib IIC T4		

VIB 5.917 : Output module with two SPDT relays for VIBRONET Signalmaster

1

2

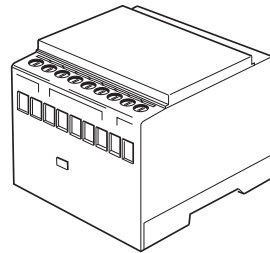

Application

This module provides two SPDT relays for the output of binary signals.

Function

The module has an LED display and two independent SPDT relays that can each be controlled by a digital output of the VIBRONET Signalmaster.

Technical data

PARAMETER		VIB 5.917
Electrical	Number of relay outputs	2
	Supply voltage	12 VDC
	Supply current	< 50 mA
	Permanent current of relay contact	< 5 A
	Voltage at relay contact	< 50 V
	Voltage at relay contact	< 20 W
	Bounce time of relay contact	5 ms
	Voltage endurance between contact and coil	750 V-
	Number of switching cycles	2 x 10 ⁸
	General	Operating temperature
Mechanical load		Shock: 30g / Vibration: 2 g constant acceleration at 10 to 150Hz
Screw connection		Fine wire 2.5 mm ² AWG 12, Single wire 4 mm ² AWG 12
Tightening torque		0.5 - 1.0 Nm
Weight		100 g
Housing material		Polyamide
Mounting (Option)		Supporting rail TS35
Dimensions (L x W x H)		approx. 50 x 125 x 55 mm

Terminal connections

Terminal	Function
1	12 VDC
2	PG
3	SW1
4	SW2
5	Opener1
6	COM1
7	COM1
8	Closer1
9	Opener2
10	COM2
11	COM2
12	Closer2

12VDC/60mA 12V DC current supply
 PG Reference zero for the 12V supply
 SW Control input for relay (5-24V)
 Opener Opener of the change-over contact
 COM Root of the change-over contact
 Closer Closer of the change-over contact

VIB 5.973 : Terminal with voltage limitation, 5 Volt

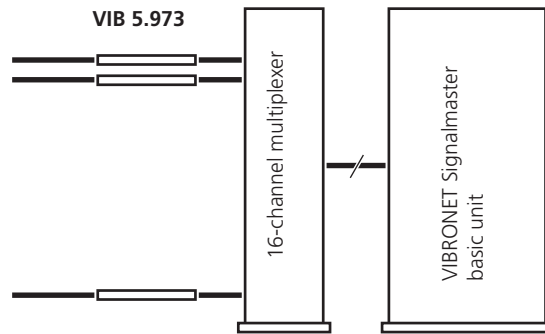
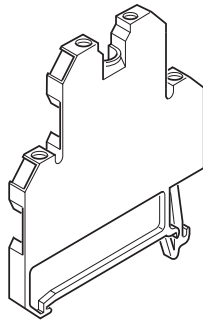

1
2

Application and function

This terminal limits the voltage to a maximum value of 5 volt. The output voltage of the terminal follows the linear input voltage up to a level of 5 volt. Higher input voltages lead to no further increase of the output voltage.

Uses include, e.g. the connection of 24V signals to the digital inputs of a VIBRONET Signalmaster system or the connection of pulse signals with amplitudes of more than 5 volt to the counter inputs of a VIBRONET Signalmaster system.

Technical data

PARAMETER		VIB 5.973
Electrical	Input voltage	< 40 V
	Output voltage	< 5 V
	Input resistance	1200 Ohm
	Contact resistance	4700 Ohm
General	Operating temperature	-40°C ... +85°C
	Mechanical load	Shock: 30g / Vibration: 2 g constant acceleration at 10 to 150Hz
	Screw connection	0.5 .. 4 mm ² / AWG 22..12
	Color coding	IN+ red, IN- black, OUT+ green, OUT- black
	Tightening torque	0.5 - 1.0 Nm
	Weight	18 g
	Housing material	Polyamide
	Mounting (Option)	Supporting rail TS35
	Dimensions (H x D x W)	approx. 50 x 53 x 7.7 mm

Terminal connections:

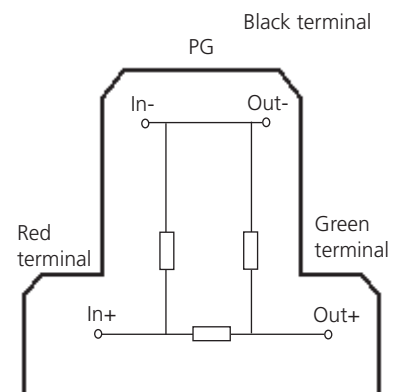

1

2

Chapter 2

VIBRONET Signalmaster accessories



16-channel multiplexers for VIBRONET Signalmaster

1

VIB 5.818-N : 16-channel multiplexers for ICP-type or Current LineDrive accelerometers

VIB 5.818-NEV : 16-channel multiplexers for event recording

VIB 5.819-4x4 : 16-channel multiplexers with 4x4 synchronous inputs

VIB 5.819-8x2 : 16-channel multiplexers with 8x2 synchronous inputs

2

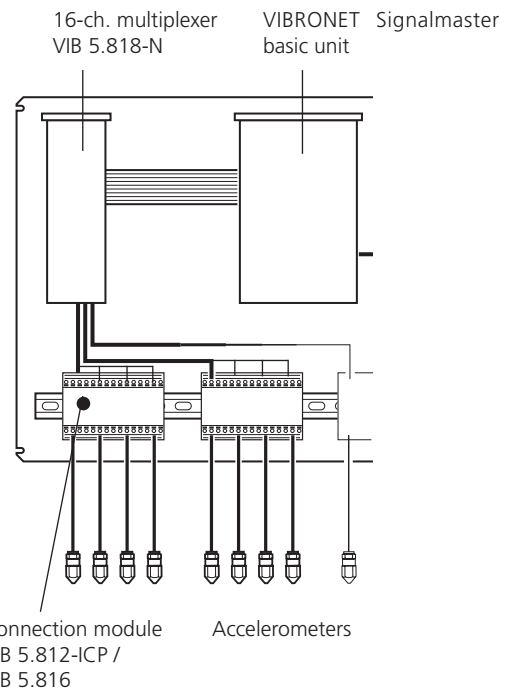
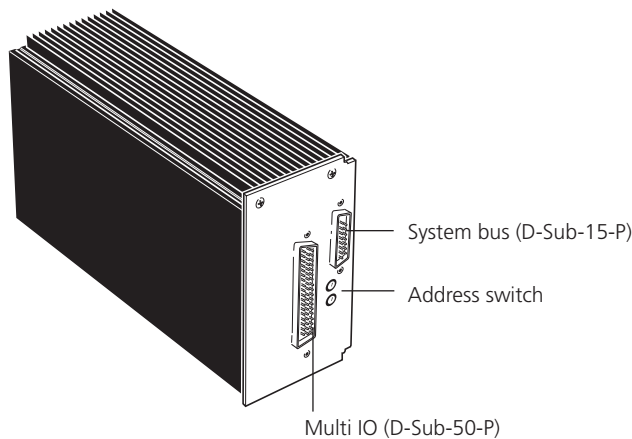

Application

A multiplexer multiplies the analog inputs of the VIBRONET Signalmaster basic unit by joining a freely selectable combination of 16 channels.

- VIB 5.818-N:
The 16 channels are joined to a single analog input of the basic unit.

- VIB 5.818-NEV:
This multiplexer is used for the fast event-controlled data recording of up to 16 analog channels. Further characteristics: Event, rainflow, dwell continuous count

Sampling rate depends on the number of channels:

CHANNELS		Sampling rate in Hz
VIB 5.818-NEV	16	400, 300, 200, 150, 100, 75, 50, 40, 30, 20, 15, 10, 2, 1
	8	800, 600
	4	1600, 1200
	2	3200, 2400
	1	6400, 4800

VIB 5.819-4x4:

The 16 channels are combined in four banks, each with four channels, and fed to four* synchronous inputs of the basic unit.

* 3 analog inputs, 1 TTL input for key phaser

VIB 5.819-8x2:

The 16 channels are joined to form two banks, each with 8 channels, and fed to two synchronous inputs of the basic unit.

Description

Semiconductor elements are used to switch over the channels that are characterized by a minimum current consumption and short switchover times. The current supply and addressing follow via the system bus. The multiplexer modules are suitable for autonomous use in an industrial environment.

Expansion

Up to 8 multiplexers (theoretical: 254) can be connected to the VIBRONET Signalmaster unit. Thus, multiplexers multiplies an analog input to a total of 128 (=16 x 8) analog inputs.

General notes

Optionally, an individual voltage divider and voltage limiter can be inserted in front of each channel. This enables status and analog signals >10V to be recorded at the same time using a multiplexer.

Note on differential measurements

For signals from signal sources with their own voltage supply that are not connected via PG, low inputs above 10 kOhm must be connected using PGs.

Notes on the preamplifier

For the multiplexer VIB 5.818-N and the multiplexer VIB 5.819-8x2, a preamplifier can be inserted for each bank. The preamplifier has the ranges 1, 10, 100, 1000. For the multiplexer VIB 5.819-4x4, a preamplifier can be integrated in bank 1 and in bank 3.

1
2

Technical data

PARAMETER		VIB 5.818-N / VIB 5.818-NEV / VIB 5.819-4x4 / VIB 5.819-8x2
Electrical	Power supply	12 VDC / 2 mA
	Voltage range, analog inputs	± 10 V
	Max. over voltage, analog inputs	± 20 V
	No. of analog inputs	16 differential, freely combinable
General	Operating temperature	-20°C ... +60°C
	Mechanical load	Shock: 30g / Vibration: 2 g constant acceleration at 10 to 150Hz
	Humidity	20% to 100%, dewfall is allowed
	Weight	approx. 1 kg
	Housing material	Aluminum
	Dimensions	approx. 130 x 70 x 240 mm (H x T x B)

Addressing the multiplexers

The multiplexers are addressed via the system bus using the SDM protocol.

Theoretical up to 254 multiplexers can be connected to the VIBRONET Signalmaster. Practically the number is limited to 8 multiplexers per unit.

The count begins with the first multiplexer with address 1 ascending to 254. However, this sequence is not mandatory as any addresses in the available range can also be used.

The (decimal) addresses must be set in hexadecimal code using the coding switch on the back of the multiplexer (see figure).

Thus, hexadecimal can be used to set the decimal addresses 1-254 in hexadecimal 01 – FE:

- 1 (dec.) = 01 (hex) = x01
- 254 (dec.) = FE (hex) = xFE.

The first symbol (numeral or letter) in hexadecimal code corresponds to the 'high nibble', and the second symbol corresponds to the 'low nibble'.

Example: FE where F = high nibble and E = low nibble. This represents the decimal address 254.

The address 255 (dec.) or FF (hex) cannot be used as it is reserved for a collective reset.

With the operation of two multiplexers, the addresses are set up as follows:

- 1st multiplexer: High nibble = 1
Low nibble = 0
- 2nd multiplexer: High nibble = 2
Low nibble = 0

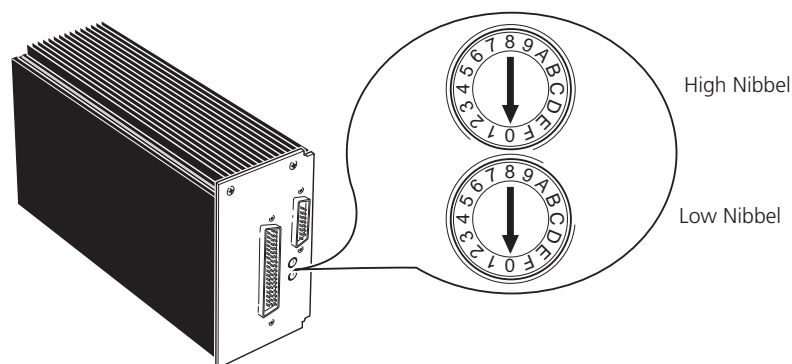

Terminal connections: System bus (Sub-D 15)

SUB-D 15	VIB 5.818-N	VIB 5.818-NEV	VIB 5.819-4x4	VIB 5.819-8x2
1	nc	Hi3	Hi3	Hi3
2	nc	Lo3	Lo3	Lo3
3	AG	AG	AG	AG
4	nc	MUX-CLK	nc	nc
5	12 V	12 V	12 V	12 V
6	PG	PG	PG	PG
7	SDM1	nc	SDM1	SDM1
8	SDM2	MUX-Reset	SDM2	SDM2
9	SDM3	nc	SDM3	SDM3
10	nc	nc	Hi4	nc
11	nc	nc	Lo4	nc
12	Hi1	nc	Hi1	Hi1
13	Lo1	nc	Lo1	Lo1
14	nc	nc	Hi2	nc
15	nc	nc	Lo2	nc

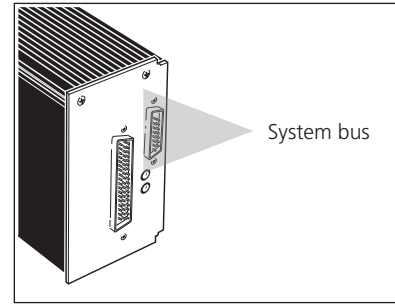

- 12V 12V DC current supply
- AG Analog reference zero
- PG Power ground
- SDM A-wire for triggering
- HiLo Analog signal line
- MUC-CLK Impulse for channel switching

Terminal connections: Multi IO (Sub-D 50)

SUB-D 50	VIB 5.818-N	VIB 5.818-NEV	VIB 5.819-4x4	VIB 5.819-8x2
1	B1-In-H1	B1-In-H1	B1-In-H1	B1-In-H1
2	B1-In-H2	B1-In-H2	B1-In-H2	B1-In-H2
3	B1-In-H3	B1-In-H3	B1-In-H3	B1-In-H3
4	B1-In-H4	B1-In-H4	B1-In-H4	B1-In-H4
5	B1-In-H5	B1-In-H5	B2-In-H1	B1-In-H5
6	B1-In-H6	B1-In-H6	B2-In-H2	B1-In-H6
7	B1-In-H7	B1-In-H7	B2-In-H3	B1-In-H7
8	B1-In-H8	B1-In-H8	B2-In-H4	B1-In-H8
9	B1-In-H9	B1-In-H9	B3-In-H1	B2-In-H1
10	B1-In-H10	B1-In-H10	B3-In-H2	B2-In-H2
11	B1-In-H11	B1-In-H11	B3-In-H3	B2-In-H3
12	B1-In-H12	B1-In-H12	B3-In-H4	B2-In-H4
13	B1-In-H13	B1-In-H13	B4-In-H1	B2-In-H5
14	B1-In-H14	B1-In-H14	B4-In-H2	B2-In-H6
15	B1-In-H15	B1-In-H15	B4-In-H3	B2-In-H7
16	B1-In-H16	B1-In-H16	B4-In-H4	B2-In-H8
17	AG	AG	AG	AG
18	B1-In-L1	B1-In-L1	B1-In-L1	B1-In-L1
19	B1-In-L2	B1-In-L2	B1-In-L2	B1-In-L2
20	B1-In-L3	B1-In-L3	B1-In-L3	B1-In-L3
21	B1-In-L4	B1-In-L4	B1-In-L4	B1-In-L4
22	B1-In-L5	B1-In-L5	B2-In-L1	B1-In-L5
23	B1-In-L6	B1-In-L6	B2-In-L2	B1-In-L6
24	B1-In-L7	B1-In-L7	B2-In-L3	B1-In-L7
25	B1-In-L8	B1-In-L8	B2-In-L4	B1-In-L8
26	B1-In-L9	B1-In-L9	B3-In-L1	B2-In-L1
27	B1-In-L10	B1-In-L10	B3-In-L2	B2-In-L2
28	B1-In-L11	B1-In-L11	B3-In-L3	B2-In-L3
29	B1-In-L12	B1-In-L12	B3-In-L4	B2-In-L4
30	B1-In-L13	B1-In-L13	B4-In-L1	B2-In-L5
31	B1-In-L14	B1-In-L14	B4-In-L2	B2-In-L6
32	B1-In-L15	B1-In-L15	B4-In-L3	B2-In-L7
33	B1-In-L16	B1-In-L16 Eventbus	B4-In-L4	B2-In-L8
34 - 50	AG	AG	AG	AG

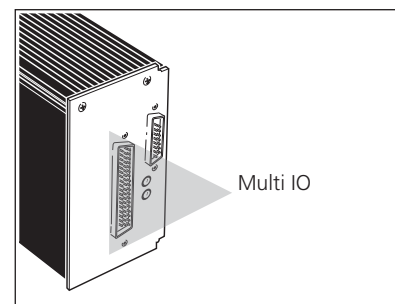

- B1-In Hx, Lx
- 16x analog input (±10V)
 - 4x4 analog input (±10V); Synchronous through switching of the channels (bank 1 B1 to bank 4 B4) to the system bus.
 - 8x2 analog input (±10V); Synchronous through switching of the channels (bank 2 B2 to bank 2 B2) to the system bus.
- AG Analog reference zero
Event Bus Supply, control and analog signal

VIB 5.816 : Connection module for Current LineDrive accelerometers

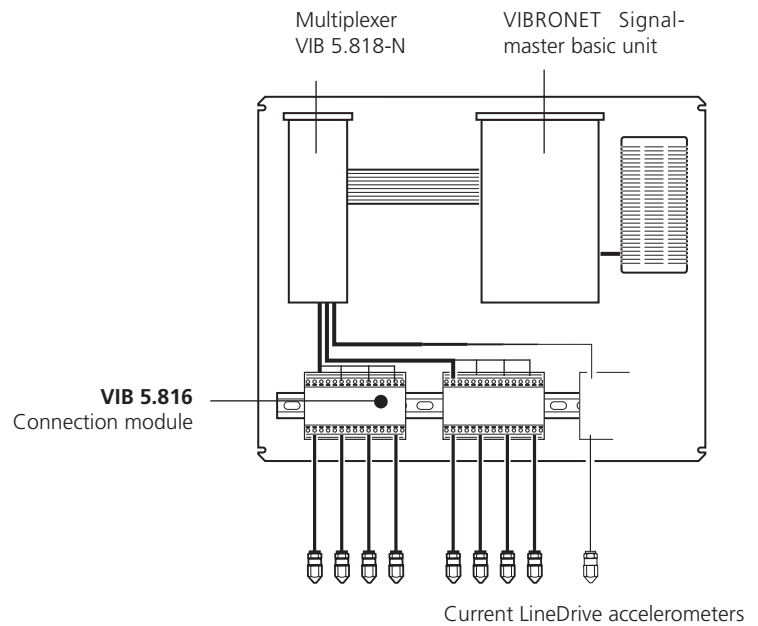
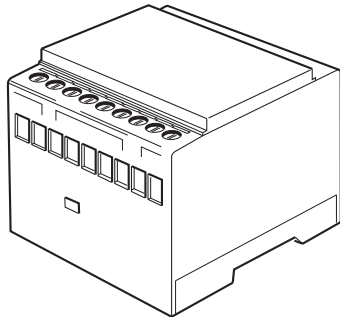

1
2

Application

Connection of transducers with current line drive output to the VIBRONET Signalmaster.

Function

The current line drive signals from the transducer are converted into a voltage signal for the VIBRONET Signalmaster by a current mirror circuit integrated in the module.

Technical data

PARAMETER		VIB 5.816
Electrical	Number of signal inputs	4
	Supply voltage	12 VDC
	Current cons. with 4 transducers	< 50 mA
	Transducer type	Current LineDrive
	Scaling	1µA = 1mV
General	Operating temperature	-40°C ... +85°C
	Mechanical load	Shock: 30g / Vibration: 2 g constant acceleration at 10 to 150Hz
	Screw connection	Fine wire 2.5 mm ² AWG 12, Single wire 4 mm ² AWG 12
	Tightening torque	0.5 - 1.0 Nm
	Weight	100 g
	Housing material	Polyamide
	Mounting	Supporting rail TS35
Dimensions (L x W x H)	approx. 50 x 75 x 55 mm	

Terminal connections

Terminal	Function	
VIB 5.816	1	12 VDC / 50 mA
	2	+OUT1
	3	-OUT1
	4	+OUT2
	5	-OUT2
	6	+OUT3
	7	-OUT3
	8	+OUT4
	9	-OUT4

Terminal	Function	
VIB 5.816	10	PG
	11	+IN1
	12	-IN1
	13	+IN2
	14	-IN2
	15	+IN3
	16	-IN3
	17	+IN4
	18	-IN4

Terminal description

12VDC/50mA 12V DC power supply
 PG Reference zero for the 12V power supply
 OUT Output signal
 IN Connection for accelerometer

VIB 5.812-ICP : Connection module for ICP-type accelerometers

1

2

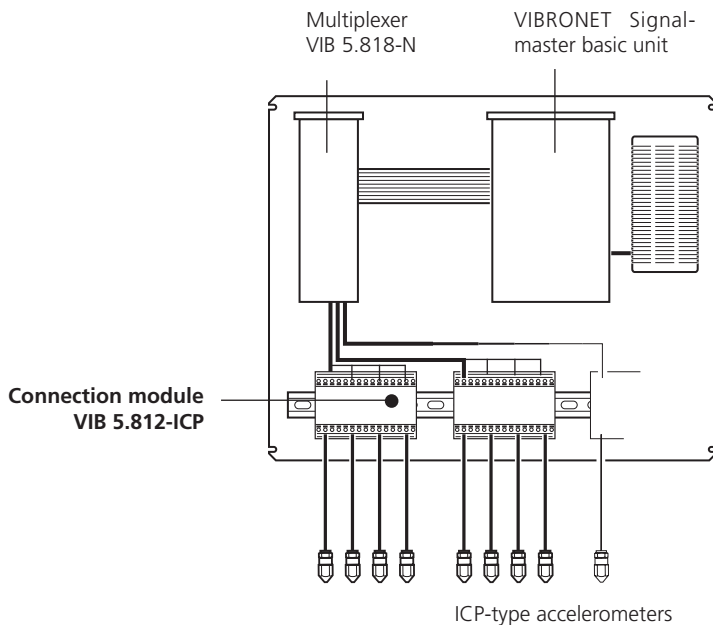
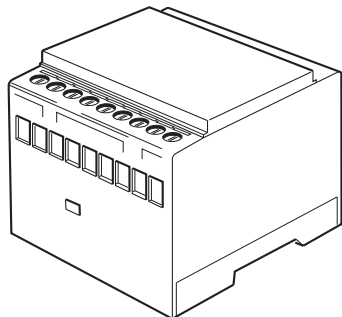

Application

Connection of transducers with ICP-type output to the VIBRONET Signalmaster.

The module provides four inputs with an ICP power supply. ICP-type accelerometers and microphones can be connected.

Function

The input signal runs through a high pass filter with a 0.3 Hz cutoff frequency and an impedance transformer for buffering the output signals.

Technical data

PARAMETER		VIB 5.812-ICP
Electrical	Number of signal inputs	4 ICP signal inputs
	Number of signal outputs	4 voltage outputs
	Power supply	12 VDC / 40 mA
	ICP supply	2 mA / 24 V
	Transmission factor	1 mV/mV
	Transmission accuracy	0.1% of input
	Signal filter	HP: 0.3 Hz
	Input range	DC range with $6V_{rms}$ + AC component
General	Operating temperature	-40°C ... +85°C
	Mechanical load	Shock: 30g / Vibration: 2 g constant acceleration at 10 to 150Hz
	Screw connection	Fine wire 2.5 mm ² AWG 12, Single wire 4 mm ² AWG 12
	Tightening torque	0.5 - 1.0 Nm
	Weight	100 g
	Housing material	Polyamide
	Mounting (Option)	Supporting rail TS35
	Dimensions (L x W x H)	approx. 125 x 75 x 55 mm

Terminal connections

Terminal	Function	Terminal	Function		
VIB 5.812-ICP	1	12 VDC / 40 mA	VIB 5.812-ICP	13	IN_Sensor1-
	2	PG		14	Shielding 1
	3	Sensor OK		15	IN_Sensor2+
	4	OUT_a1Hi		16	IN_Sensor2-
	5	OUT_a1Lo		17	Shielding 2
	6	OUT_a2Hi		18	IN_Sensor3+
	7	OUT_a2Lo		19	IN_Sensor3-
	8	OUT_a3Hi		20	Shielding 3
	9	OUT_a3Lo		21	IN_Sensor4+
	10	OUT_a4Hi		22	IN_Sensor4-
	11	OUT_a4Lo		23	Shielding 4
	12	IN_Sensor1+			

Terminal description

12VDC/40mA	12V DC current supply
PG	Reference zero for the 12V supply
OUT_a	Buffered signal
IN sensor	Connection for acceleration transducer
Shielding	Reference zero for shielding

VIB 5.910 : Add-on module for digital output

1

2

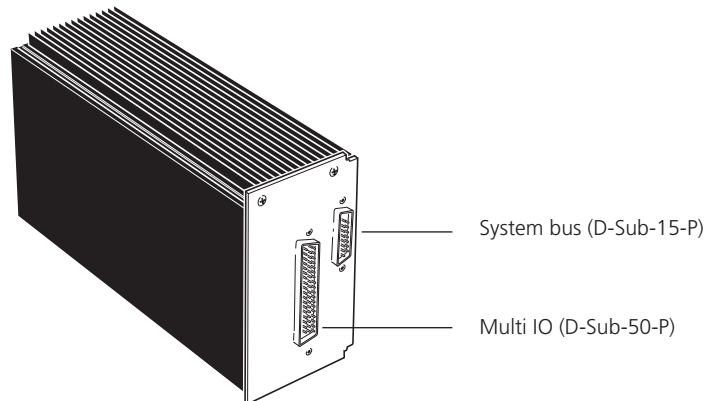

Application

This module is used to expand the number of digital outputs in the VIBRONET Signalmaster by 16 outputs.

Function

The digital outputs are configured as semiconductor switches with a fuse. The maximum switching voltage is 40 VDC. The maximum switching power is 20W. The self-restoring thermal fuse holds the current up to 0.5 A.

Expansion

Up to 14 modules can be connected to a Signalmaster base unit.

Note

The connecting line to the VIBRONET Signalmaster can be up to 6 meters long.

Technical data

PARAMETER		VIB 5.910
Electrical	Power supply	12 VDC / 2 mA
	Digital outputs	16
	Type	FET switch
	Switching voltage	< 40 V
	Switching power	< 20 W
	PullUp resistors	3 kOhm
	Output fuse	self-restoring thermic fuse
	Holding current	< 0.5 A
	Release current	2 A
General	Operating temperature	-20°C ... +50°C
	Mechanical load	Shock: 30g / Vibration: 2 g constant acceleration at 10 to 150Hz
	Relative humidity	10% to 100%, dewfall is allowed
	Weight	approx. 1 kg
	Housing material	Aluminium
	Dimensions (H x D x W)	approx. 130 x 70 x 250 mm

Terminal connections: System bus (Sub-D 15)

CHANNEL	Function	
VIB 5.910	1	nc
	2	nc
	3	nc
	4	nc
	5	12 V
	6	PG
	7	SDM1
	8	SDM2
	9	SDM3
	10	nc
	11	nc
	12	nc
	13	nc
	14	nc
	15	nc

nc not connected
 12 V 12V DC current supply
 PG Reference zero for the 12V supply
 SDM A-wire for triggering

Terminal connections: Multi IO (Sub-D 50)

1
2

CHANNEL	Function
1	Port_1
2	Port_2
3	Port_3
4	Port_4
5	Port_5
6	Port_6
7	Port_7
8	Port_8
9	Port_9
10	Port_10
11	Port_11
12	Port_12
13	Port_13
14	Port_14
15	Port_15
16	Port_16
17	nc

CHANNEL	Function
18	GND_1
19	GND_2
20	GND_3
21	GND_4
22	GND_5
23	GND_6
24	GND_7
25	GND_8
26	GND_9
27	GND_10
28	GND_11
29	GND_12
30	GND_13
31	GND_14
32	GND_15
33	GND_16

CHANNEL	Function
34	PU_1
35	PU_2
36	PU_3
37	PU_4
38	PU_5
39	PU_6
40	PU_7
41	PU_8
42	PU_9
43	PU_10
44	PU_11
45	PU_12
46	PU_13
47	PU_14
48	PU_15
49	PU_16
50	nc

Port_x Digital output (Open Drain)
 GND_x Reference ground for digital output (Source)
 PU_x Internal Pull Up resistor

Switching of levels

Connection to PLC

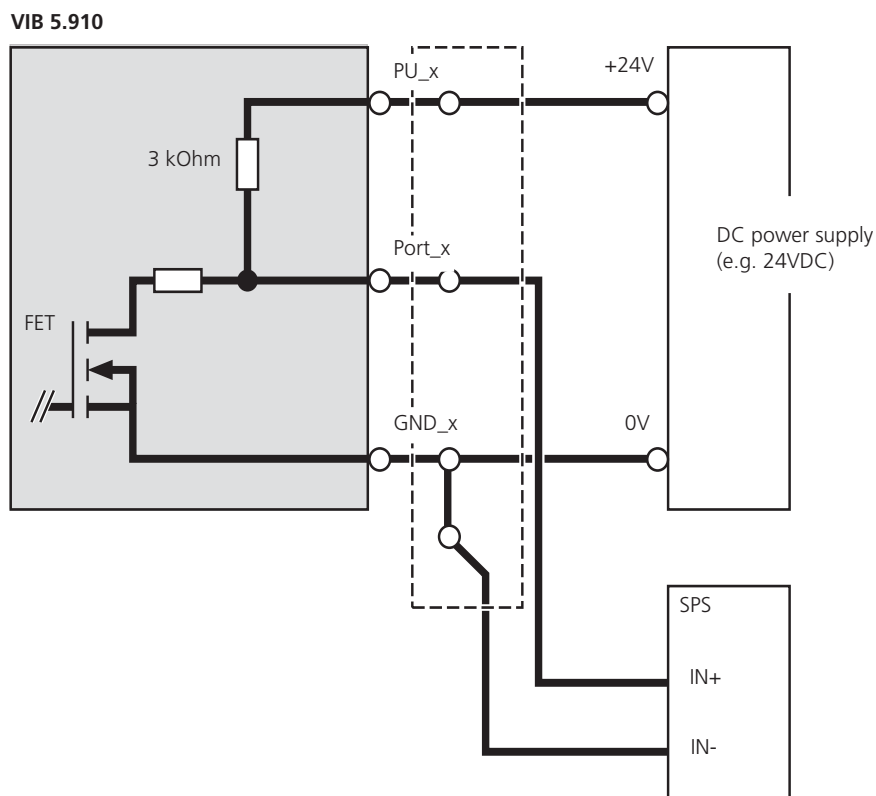

Switching of LEDs

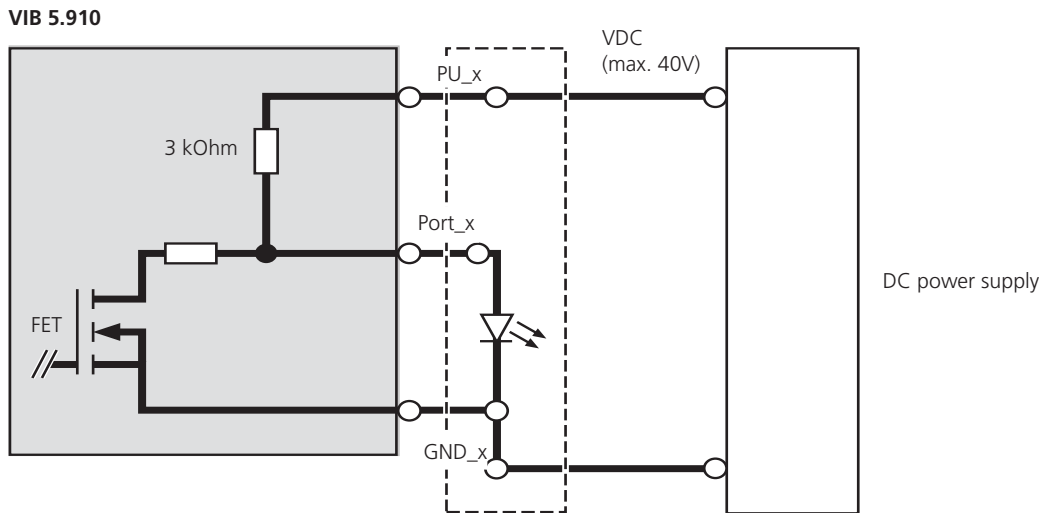

Note

The internal pull up resistor is used as a multiplier resistor for the LED.

Switching of inductive loads

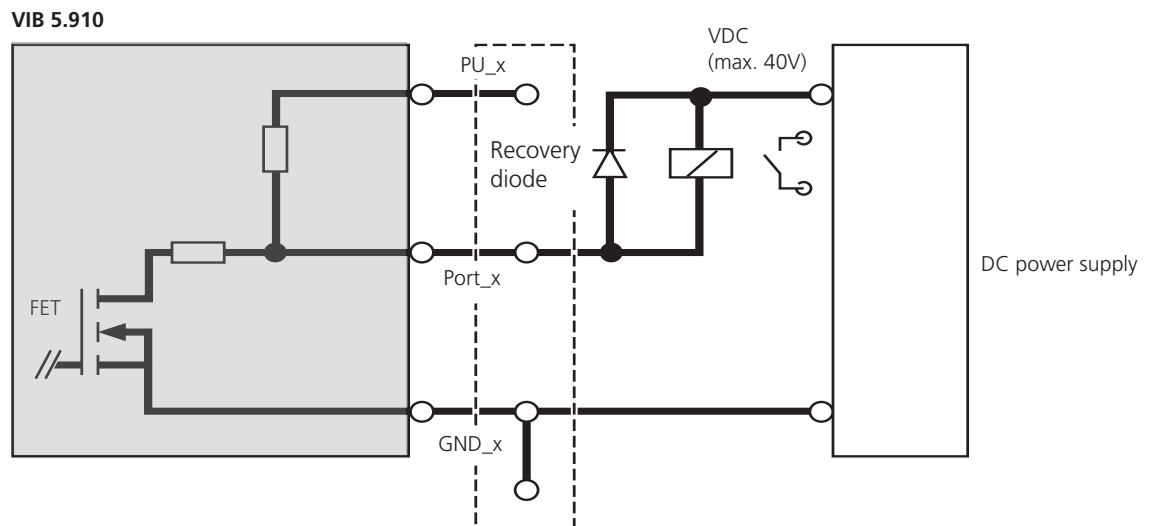

Note

When switching inductive loads (e.g. relays), a recovery diode must be switched parallel to the load.

VIB 5.959 : Industrial 5-Port ethernet switch for VIBRONET Signalmaster

1

2

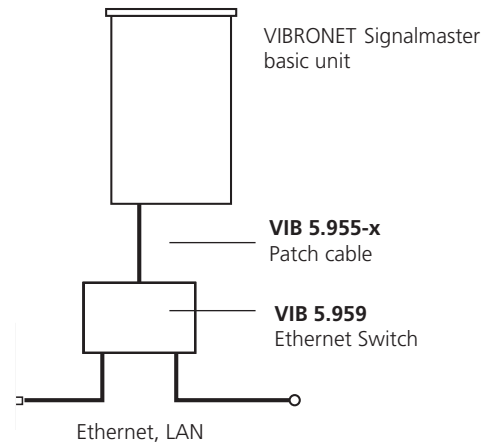
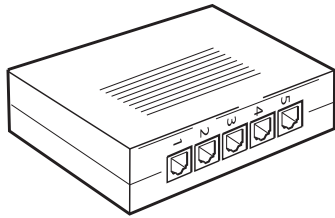

Application

The Ethernet switch is used to integrate the VIBRONET Signalmaster in a local area network.

Function

A network switch is a computer networking device that connects computers and network segments.

Technical data

PARAMETER		VIB 5.959
Data transmission	Industrial standard	IEEE 802.3, 802.3u, 802.3x
	Processing Type	Store & forward, wire speed switching
	MAC Addresses	1024
	Memory Bandwidth	1 Gbps
	Frame Buffer Memory	256 Kbit
	Flow Control	IEEE 802.3x flow control, back pressure flow control
	RJ-45 Ports	5 ports with 10/100 Base-TX auto negotiation speed, F/H duplex mode, and auto MDI/MDI-X connection
	LED Indicators	Power, 10/100M, Link/Act
General	Operating temperature	-40°C ... +75°C
	Relative humidity	max. 90%, non-condensing
	Input voltage	10 ... 30 VDC
	Power consumption	0.1 A @ 24 VDC, ±5%, 10M Full duplex 0.09A @24 VDC, ±5%, 100M Full duplex
	Weight	100 g
	Housing material	Plastic
	Dimensions (HxWxD)	approx. 99 x 33 x 78 mm

Network cables for VIBRONET Signalmaster

VIB 5.955-X : Patch cable
VIB 5.957-2 : Crossover ethernet cable, 2 m
VIB 5.957-5 : Crossover ethernet cable, 5 m

X = 2,5,10,30 m

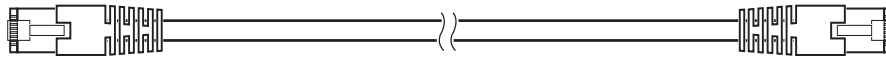

VIB 5.955-2

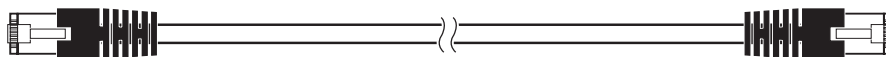

VIB 5.957-2

Application

The Patch cable VIB 5.955-X is used to connect the VIBRONET Signalmaster basic unit to a data network - either directly or via a switch.

The crossover ethernet cable VIB 5.957-X is used to connect the VIBRONET Signalmaster basic unit directly to a PC.

Technical data

PARAMETER		VIB 5.955-X	VIB 5.957-2 / -5	
Electrical	Charact. impedance	100 Ohm ±15%		
	Loop resistance	188 Ohm		
	Conductor resistance	< 94 Ohm/km		
Layout and Environment	Wire	0.52 mm Cu blk AWG24		
	Wire insulation	PE, color coding acc. to IEC 708		
	Formation	4 pairs, twisted		
	Shielding	Aluminium compound foil		
	Earth lead	0.5 mm Cu vzn		
	Sheath	FR-PVC, gray (flame resistant)	FR-LSOH, yellow (flame resistant, low-smoke, halogen-free)	
	External diameter	6.3 mm		
	Model	TP patch cable, shielded Category 5 - 100 Mbit/s, Allocation acc. to EIA/TIA 568, 4 x 2 x AWG 24/7 RJ 45 connector w/ sprayed on cable sleeve	S/FTP Crossover cable, double shielded Category 5 - 100 Mbit/s, Crossover allocation (100BASE-T4)*, 4 x 2 x AWG 26/7 RJ 45-'HIROSE' connector, yellow	
	Temperature range	-5°C ... +50°C (laying)	-30°C ... +70°C (operation)	
	Cable length	2, 5, 10 or 30 meters	2 meters or 5 meters	

*Crossover pin allocation (100BASE-T4):
 1 - 3
 2 - 6
 3 - 1
 4 - 7
 5 - 8
 6 - 2
 7 - 4
 8 - 5

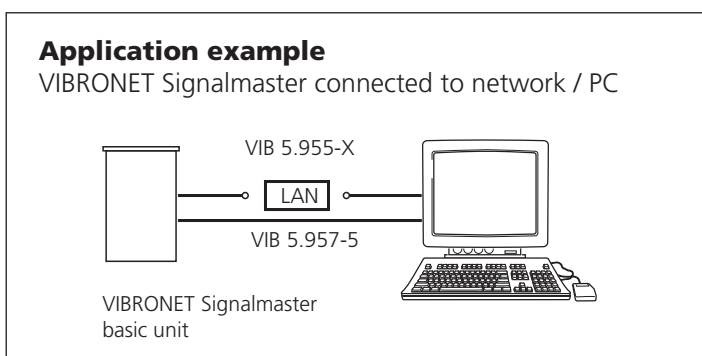

24V power supplies for VIBRONET Signalmaster

1

VIB 5.964-1,5 : Power supply for VIBRONET Signalmaster, 24 V / 1,5 A

VIB 5.964-2,5 : Power supply for VIBRONET Signalmaster, 24 V / 2,5 A

VIB 5.964-5 : Power supply for VIBRONET Signalmaster, 24 V / 5 A

2

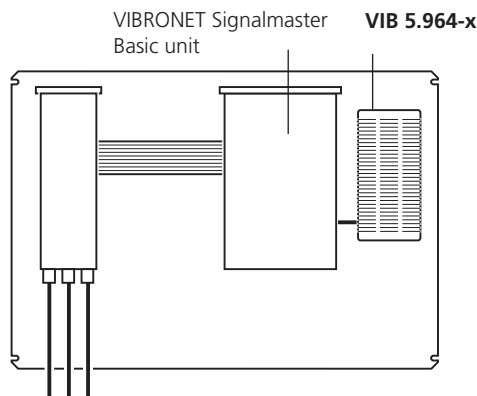
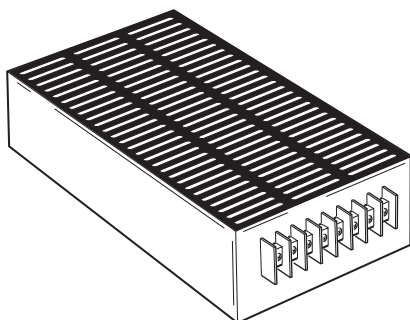

Application

The power supply is used for the power supply of 24 V devices with a maximum of 1.5 / 2.5 / 5A current consumption.

Function

The power supply has a voltage output (+24 VDC). If -24 VDC are required, the output must be reverse connected.

Notes

A top hat rail adapter for supporting rails TS 35x16 is provided on the power supply for simple assembly.

If the ambient temperature is above 50°C, the power supply must be designed with approx. double the power because power supplies are subject to a power reduction of 5% for each °C above 50°C. Furthermore, for operation with 115 VAC, a power reduction of 10-15% must be considered.

Technical data

PARAMETER		VIB 5.964-1,5	VIB 5.964-2,5	VIB 5.964-5
Electrical	Input voltage	85...264 VAC / 50...60Hz		
	Input current	0.7 A (115 VAC) 0.48 A (230 VAC)	1.2 A (115 VAC) 0.75 A (230 VAC)	--
	Switch-on peak	--	--	10 A (115 VAC) 25 A (230 VAC)
	Output	24 VDC / 1,5 A	24 VDC / 2,5 A	24 VDC / 5 A
	Power	36 W	60 W	120 W
General	Operating temperature	-10°C ... +60°C		
	Connections	Screw terminals		
	Dimensions (LxWxH)	139 x 79 x 33 mm	179 x 79 x 33 mm	213 x 111 x 39 mm

Connection terminals

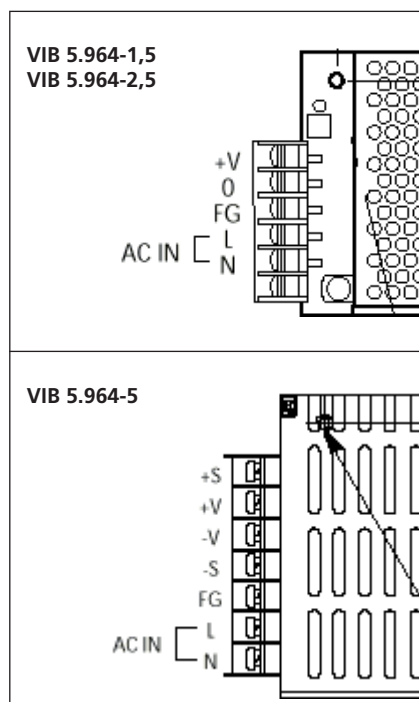

VIB 5.920-MOD: Slave connection module for Modbus Plus fieldbus system

Connection to other field bus systems (Profibus, DevNet,...) is available on request.

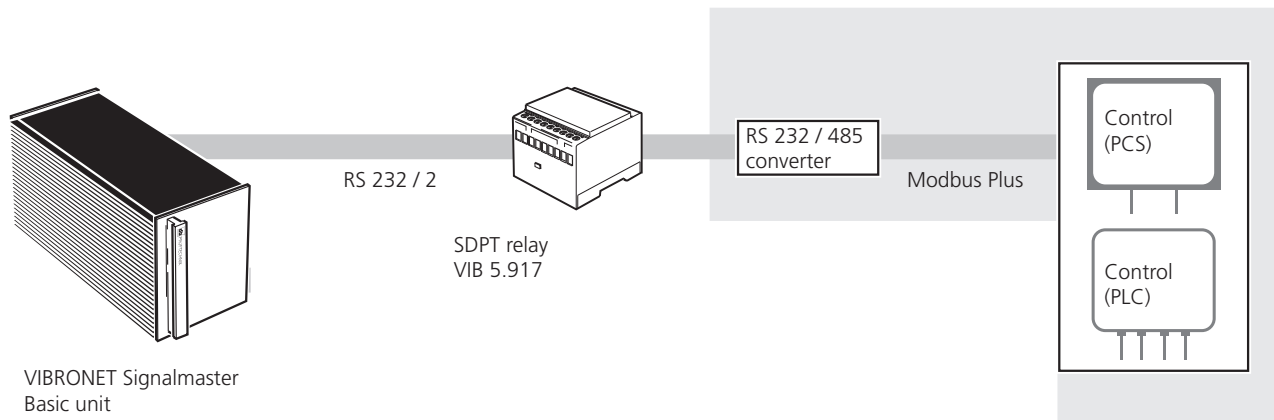

Application

To connect the VIBRONET Signalmaster system to Modbus Plus field bus.

Function

The connection to the Modbus Plus field bus is carried out internally by a special software module. The connection to the field bus is made via the second serial interface (RS 232/2) of the VIBRONET Signalmaster and an RS 232 / 485 converter.

Terminals with high-voltage fuse and transient protection

1

- VIB 5.970-M : Terminal with high-voltage fuse and transient protection for the signal cable
- VIB 5.970-P12 : Terminal with high-voltage fuse and transient protection for the 12VDC power supply
- VIB 5.970-P24 : Terminal with high-voltage fuse and transient protection for the 24VDC power supply
- VIB 5.970-P250: Terminal with high-voltage fuse and transient protection for the 250VAC power supply

2

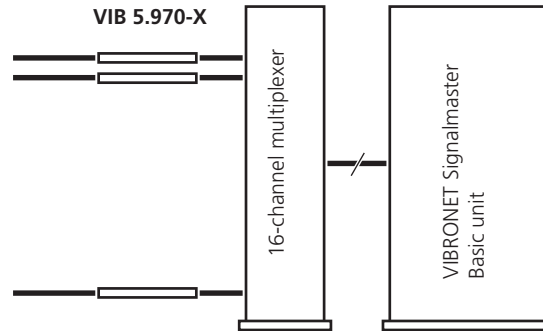
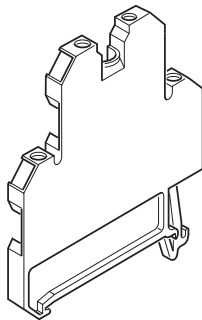

Application

VIB 5.970-M:

This terminal protects measuring inputs and transducers against excess voltages as a result of electromagnetic discharges such as lightning strikes or transients.

VIB 5.970-P12 / VIB 5.970-24:

These terminals protect 12 volt or 24 volt DC power supply inputs and DC power supply modules against excess voltages as a result of electromagnetic discharges such as lightning strikes or transients.

VIB 5.970-P250:

This terminal protects 250 volt AC power supply inputs against excess voltages as a result of electromagnetic discharges such as lightning strikes or transients.

Terminal connections:

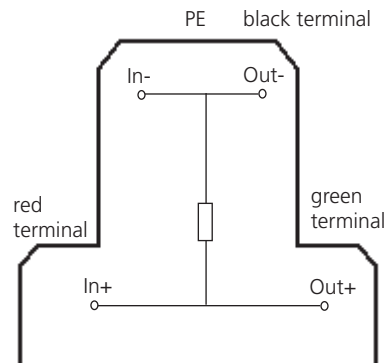

Technical data

PARAMETER		VIB 5.970-M	VIB 5.970-P12	VIB 5.970-P24	VIB 5.970-P250
Electrical	Derivation current	5 kA	0.5 kA	0.5 kA	2.5 kA
	Response voltage	90 VDC ±25%	18 VDC	38 VDC	320 VAC
	Response time	--	< 25 ns		
	Off-state voltage	11.1 V	--		
	Breakdown voltage	13.7 V	--		
	Static current	< 5 µA	--		
General	Operating temperature	-40°C ... +85°C			
	Mechanical load	Shock: 30g / Vibration: 2 g constant acceleration at 10 to 150Hz			
	Screw connection	0.5 .. 4 mm² / AWG 22..12			
	Color coding	IN red, OUT green, PE black			
	Tightening torque	0.5 - 1.0 Nm			
	Weight	18 g			
	Housing material	Polyamide			
	Mounting (Option)	Supporting rail TS35			
	Dimensions (H x D x W)	approx. 50 x 53 x 7.7 mm			

VIB 5.972 : Terminal for conversion of 20mA signals into voltage signals

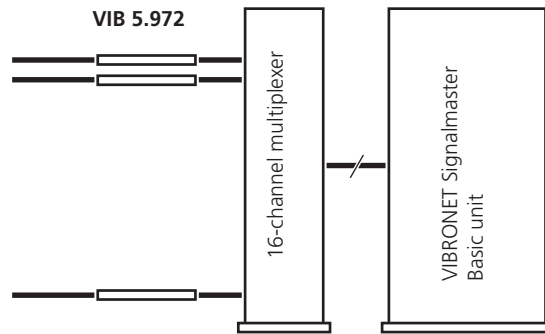
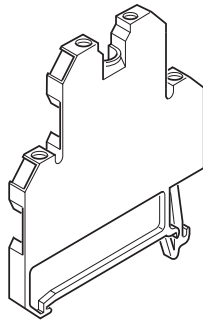

1
2

Function

This terminal converts 0-20 mA or 4-20 mA signals into voltage signals that the VIBRONET Signalmaster can handle.

Technical data

PARAMETER		VIB 5.972
Electrical	Input current	< 21 mA
	Output voltage	< 1 V
	Shunt or burden resistance	47 Ohm
	Basic accuracy of shunt resistor	0.1%
	Temperature drift of shunt resistor	25 ppm / °K
General	Operating temperature	-40°C ... +85°C
	Mechanical load	Shock: 30g / Vibration: 2 g constant acceleration at 10 to 150Hz
	Screw connection	0.5 .. 4 mm ² / AWG 22..12
	Color coding	IN+ red, IN- black, OUT+ green, OUT- black
	Tightening torque	0.5 - 1.0 Nm
	Weight	18 g
	Housing material	Polyamide
	Mounting (Option)	Supporting rail TS35
	Dimensions	approx. 50 x 53 x 7.7 mm (H x T x B)

Terminal connections:

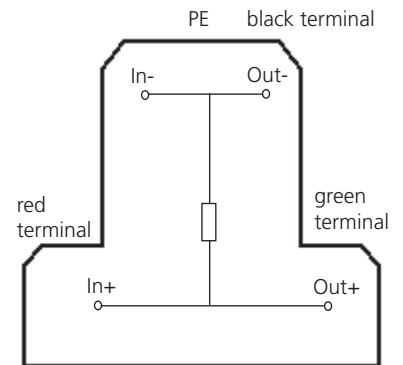

Terminals with voltage divider

1

VIB 5.974-T2 :	Terminal with voltage divider 1 / 2
VIB 5.974-T3 :	Terminal with voltage divider 1 / 3
VIB 5.974-T4 :	Terminal with voltage divider 1 / 4

2

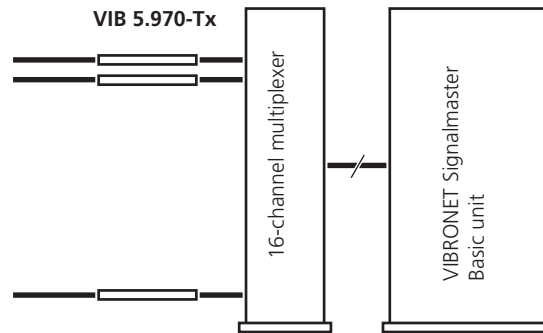
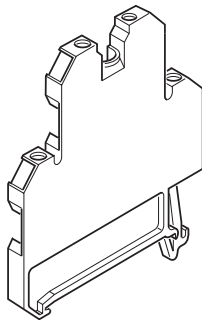

Application and function

These terminals contain a precision voltage divider with a dividing factor of 1/2 or 1/3 or 1/4 respectively. The output signal of the terminal closely follows the input signal, but with only the corresponding fraction of the input level.

The terminal VIB 5.974-T3 is suitable for transducers that operate, e.g. with unregulated ± 24 V to match their range to the VIBRONET Signalmaster.

Terminal connections:

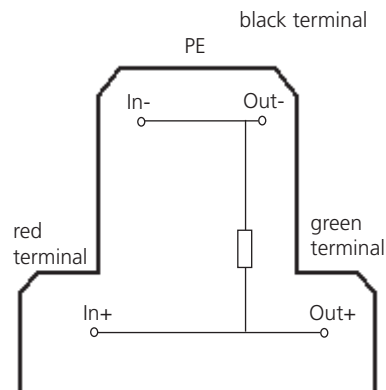

Technical data

PARAMETER		VIB 5.974-T2	VIB 5.974-T3	VIB 5.974-T4
Electrical	Input voltage	< 20 V	< 30 V	< 40 V
	Output voltage	< 10 V		
	Input resistance	136 kOhm	102 kOhm	136 kOhm
	Basic precision of voltage divider	0.2 %		
	Temperature drift of shunt resistor	30 ppm / °K		
General	Operating temperature	-40°C ... +85°C		
	Mechanical load	Shock: 30g / Vibration: 2 g constant acceleration at 10 to 150Hz		
	Screw connection	0,5 .. 4 mm² / AWG 22..12		
	Color coding	IN+ red, IN- black, OUT+ green, OUT- black		
	Tightening torque	0.5 - 1.0 Nm		
	Weight	18 g		
	Housing material	Polyamide		
	Mounting (Option)	Supporting rail TS35		
	Dimensions (H x D x W)	approx. 50 x 53 x 7.7 mm		

VIB 5.975 : Connection terminal for potential-free contact signals

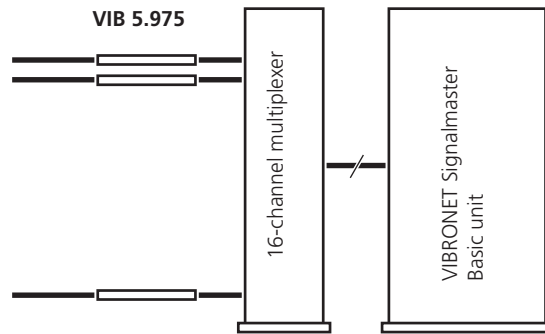
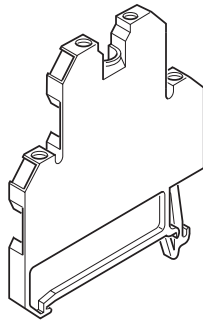

1
2

Application

This terminal is used to connect potential-free contact signals to analog multiplexers. This enables status signals to be processed, e.g. Alarm **Yes/No**, Motor running **Yes/No** or Sensor measuring **Yes/No**.

Function

Depending on the switch setting (e.g. relay contact), the terminal provides +5 volt or 0 volt at the output (IO):

Switch is closed: 0 V
Switch is open: +5 V

Technical data

PARAMETER		VIB 5.975
General	Operating temperature	-40°C ... +85°C
	Mechanical load	Shock: 30g / Vibration: 2 g constant acceleration at 10 to 150Hz
	Screw connection	0.5 .. 4 mm ² / AWG 22..12
	Color coding	IN red, OUT green, 5V black
	Tightening torque	0.5 - 1.0 Nm
	Weight	15 g
	Housing material	Polyamide
	Mounting (Option)	Supporting rail TS35
	Dimensions	approx. 50 x 53 x 7.7 mm (H x D x W)

Terminal connections:

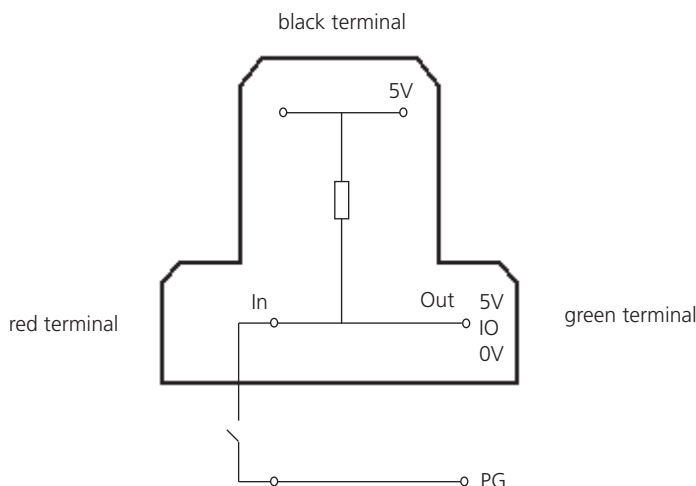

OMNITREND for VIBRONET Signalmaster, Standard

1

VIB 8.957 :	OMNITREND for VIBRONET Signalmaster Standard, software package
VIB 5.883 :	VIBRONET Signalmaster device driver for OMNITREND
VIB 8.957-P :	PC licence for VIBRONET Signalmaster

2

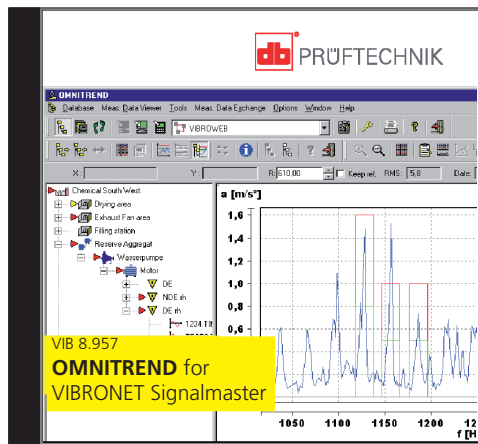

VIB 8.957
OMNITREND for
VIBRONET Signalmaster

The OMNITREND software package **VIB 8.957** contains the CD ROM and the following items:

- VIB 8.957-P PC licence
(Communication password for a VIBRONET Signalmaster basic unit)
- VIB 8.957-OMT Password certificate
(Registration of the OMNITREND full version; will only be sent out after the request for the registration password ('Return fax') has been received.)
- VIB 9.631.G OMNITREND, Getting started

The device driver **VIB 5.883** is required to operate the OMNITREND software already available with the VIBRONET Signalmaster. The VIB 5.883 contains:

- VIB 8.957-P PC licence
(Communication password for a VIBRONET Signalmaster basic unit)
- VIB 8.957-OMT Password certificate
(Registration of the OMNITREND full version; will only be sent out after the request for the registration password ('Return fax') has been received.)
- VIB 9.631.G OMNITREND, Getting started

Each further VIBRONET Signalmaster basic unit is registered with a separate **VIB 8.957-P** PC license.

Order information

To simplify the order processing, please fax any existing registration certificates when ordering.

Installation examples

1
2

Installation example A:
Monitoring of complex individual aggregates or smaller groups of aggregates (max. 37 sensors).

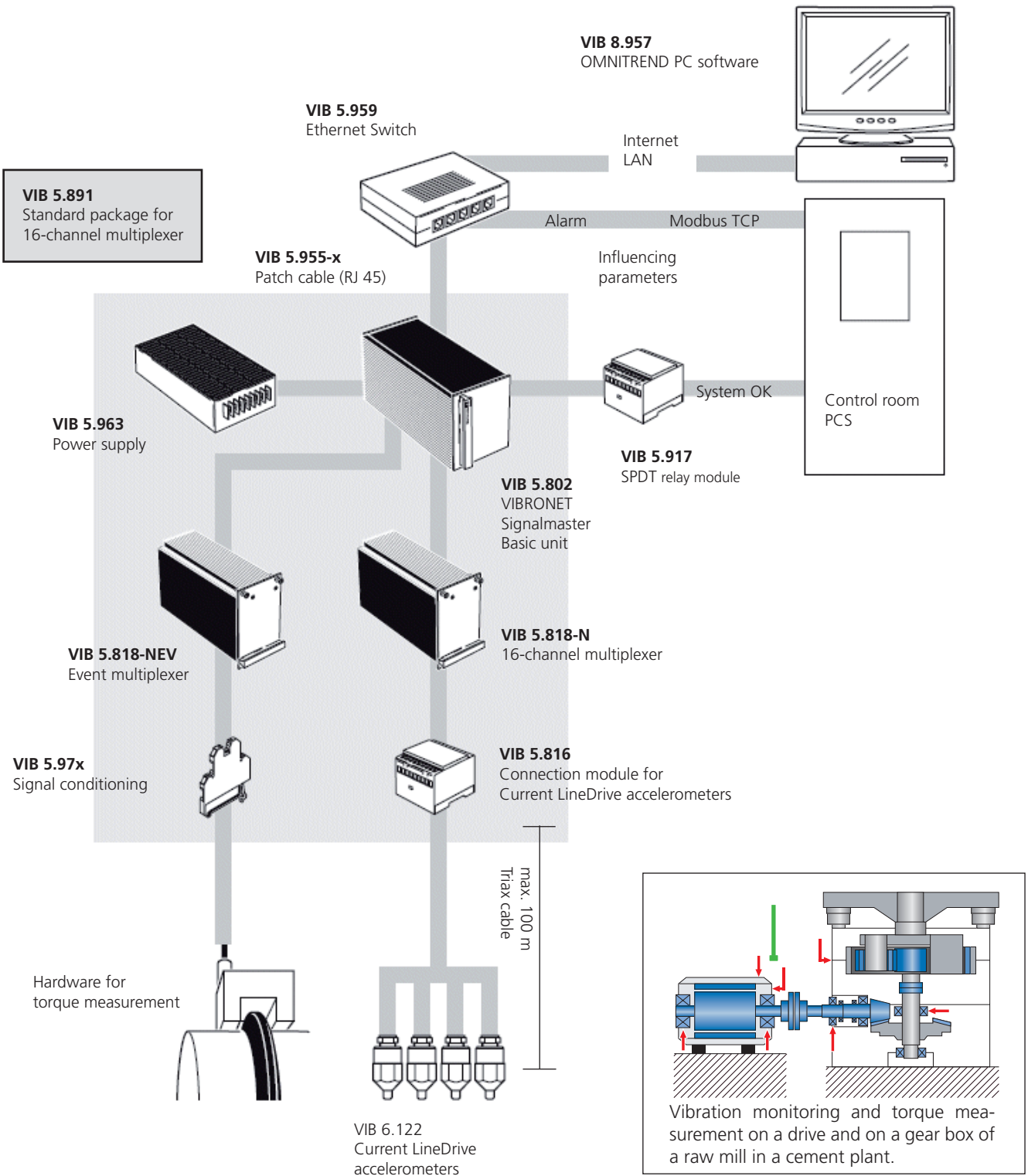

Installation example B:

Monitoring of many individual aggregates in widespread systems (max. 108 sensors in multiplexed operation).

1

2

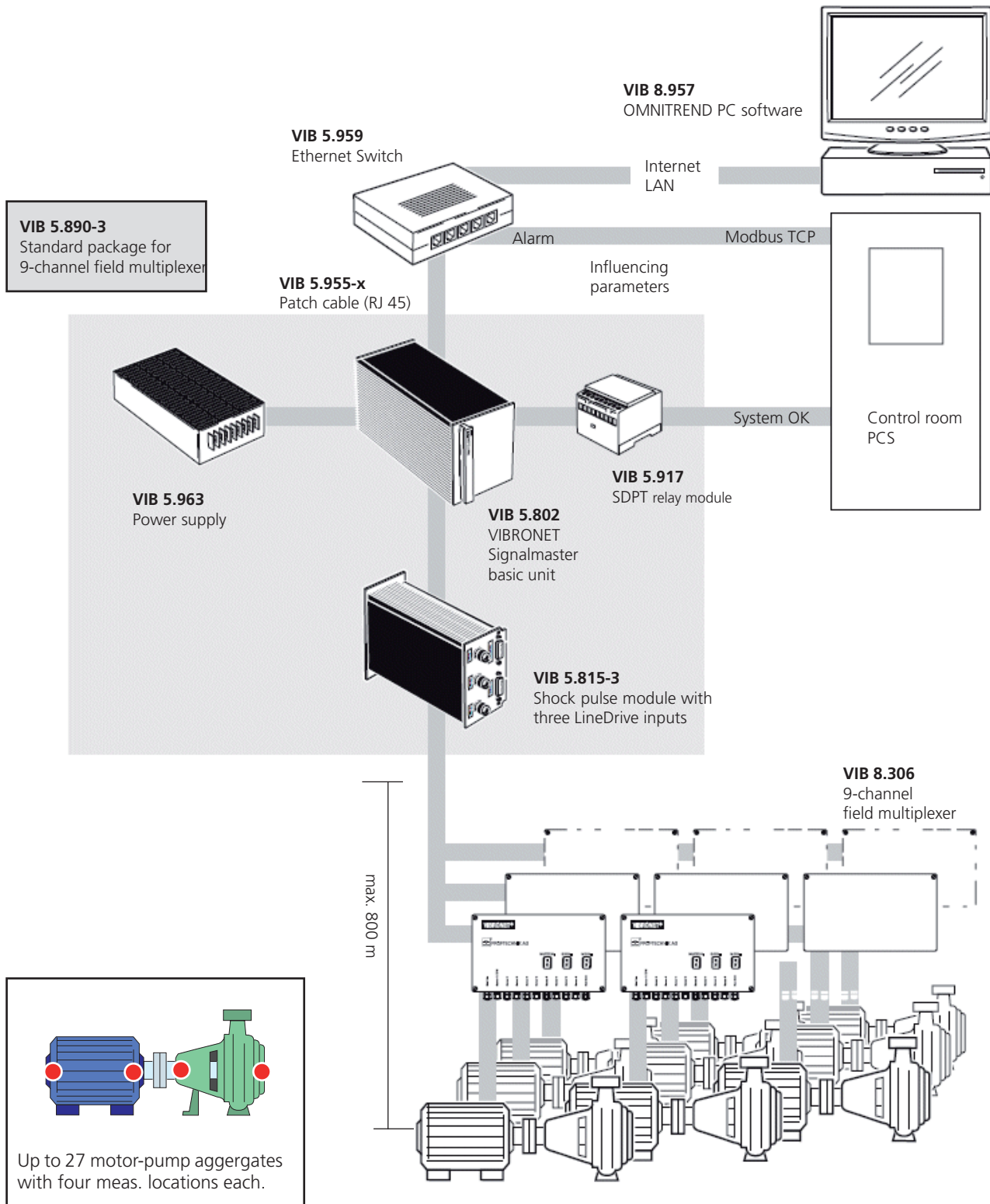

Communication example:

Local communication via ethernet (LAN/ WAN), global data exchange via internet.

Note:

Special communication solutions upon request (e.g. GPRS router with fixed IP address and secure connection via VPN).

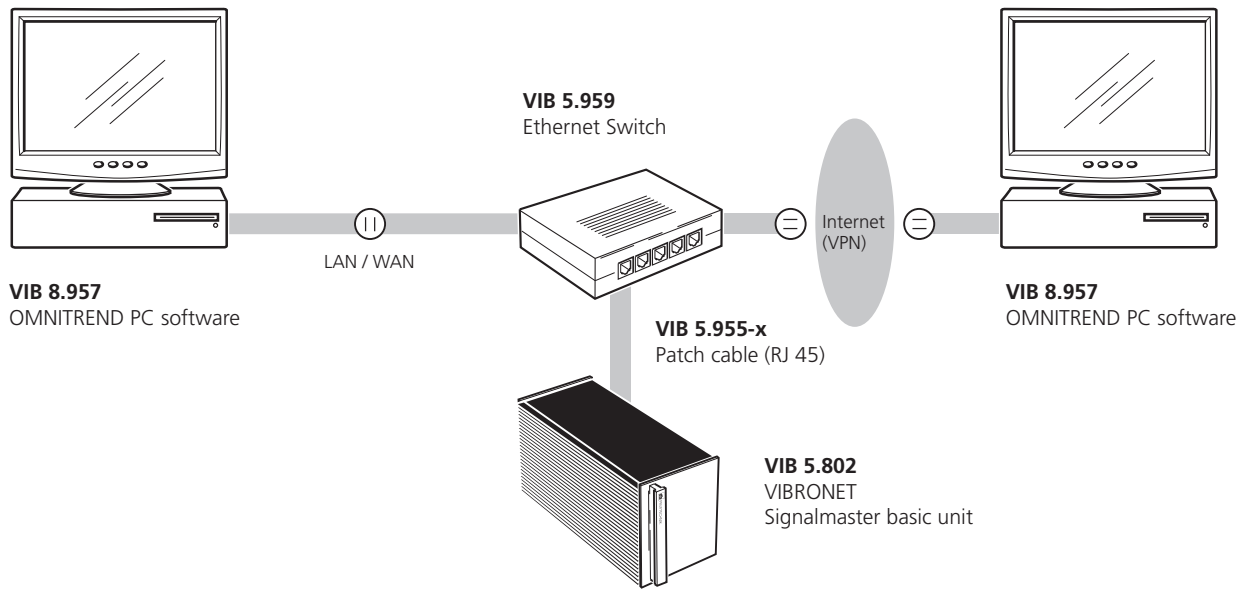

1
2

Interfaces to transducers:

Connection to accelerometers (ICP, Current LineDrive) and microphone via connection module.

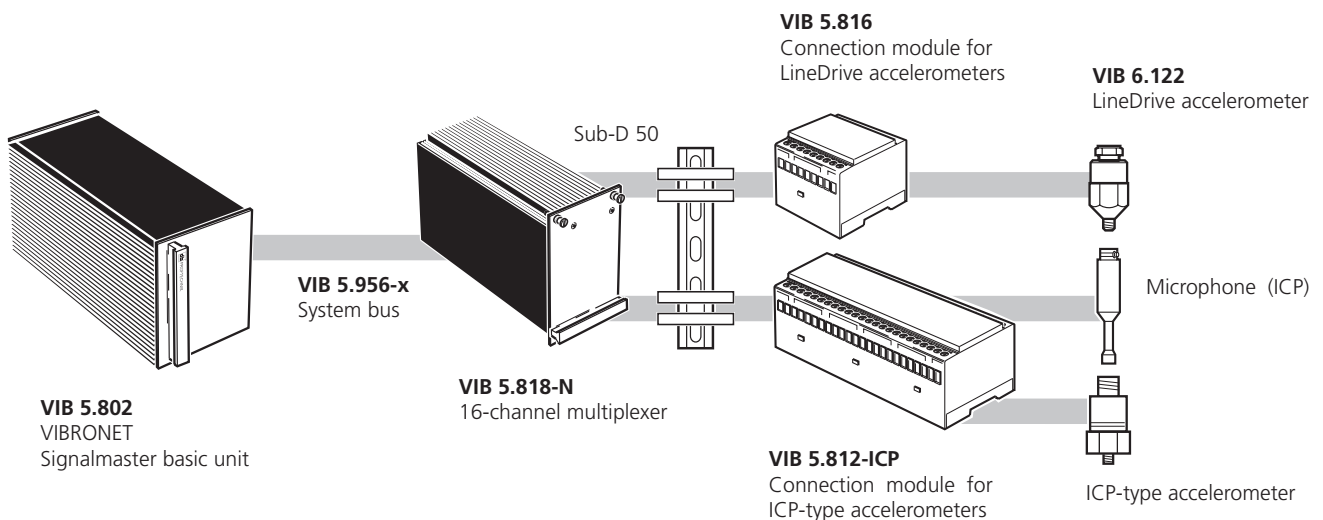

Interfaces to transducers:

Connection via field multiplexer (VIB 8.306) and shock pulse module (VIB 5.815-1).

1

2

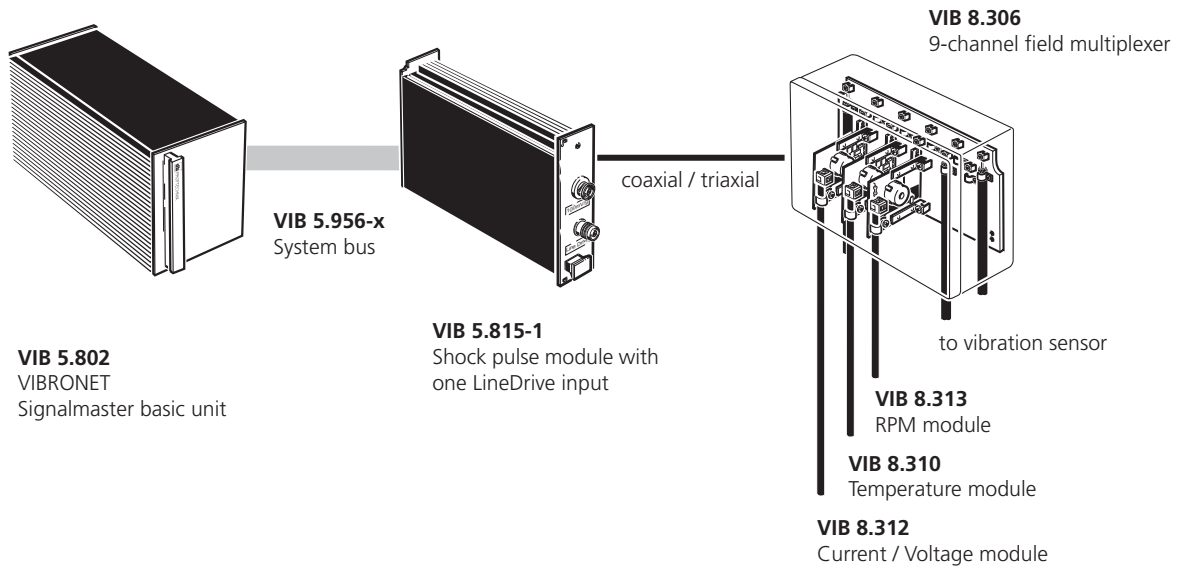

Interfaces to transducers:

Displacement measurement via multiplexer with 4x4 synchronous inputs. Orbit with displacement transducers and key phaser.

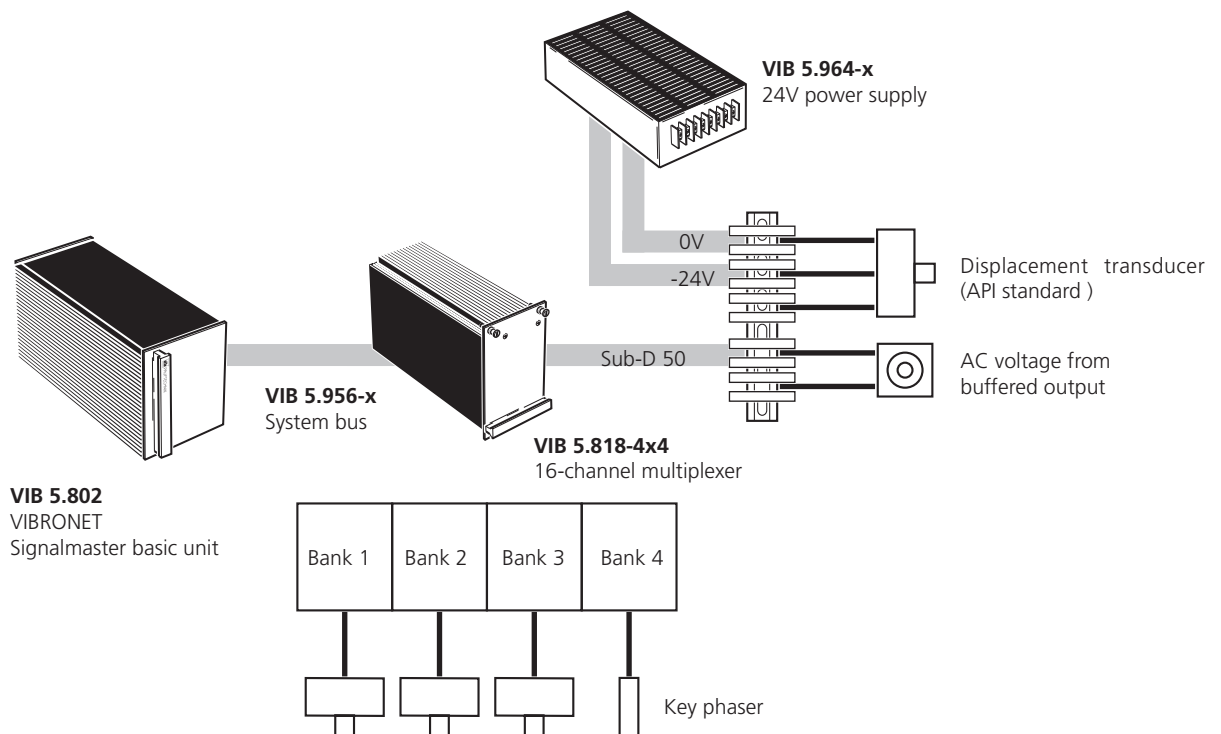

Interfaces to PCS / PLC:

Connection to control systems via multiplexer and digital input modules (up to 16 inputs per module).

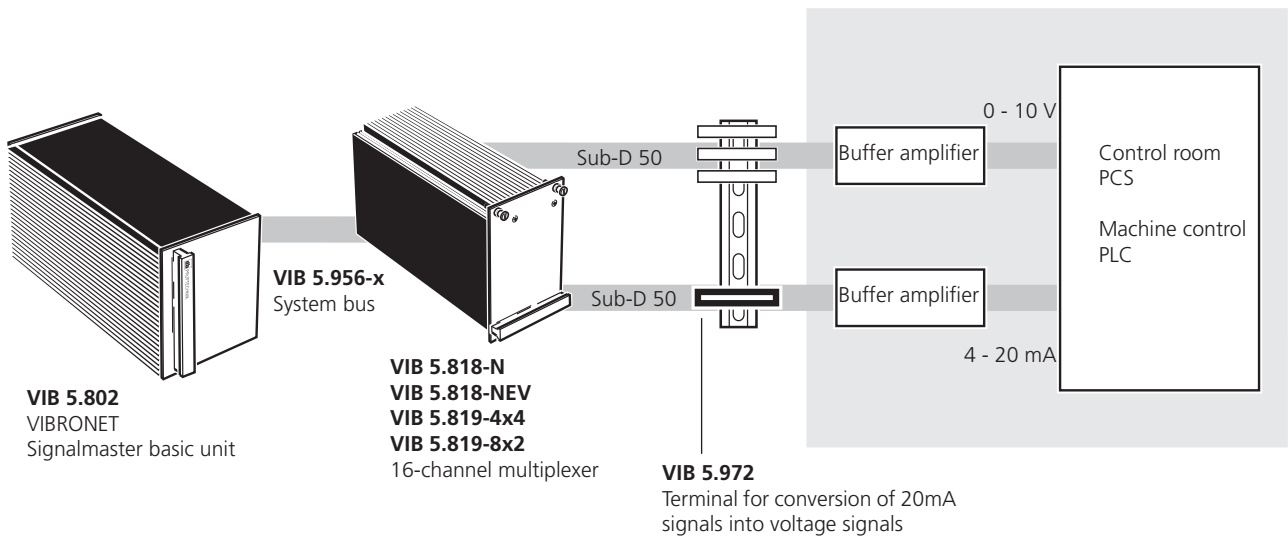

1
2

Interfaces to PCS / PLC:

Connection to fieldbus via internal software module (Modbus Plus, Modbus RTU, ProfiNET, Profibus).

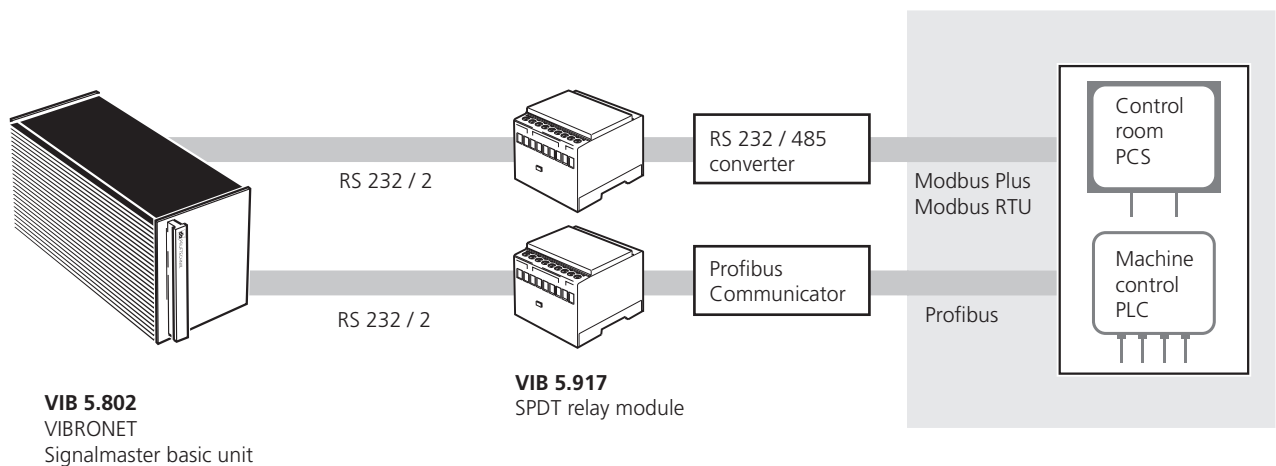

Interfaces to PCS / PLC:

Direct connection to control systems via internal digital In-/ Outputs (up to 4 dig. I/O and 4 dig. Out).

1

2

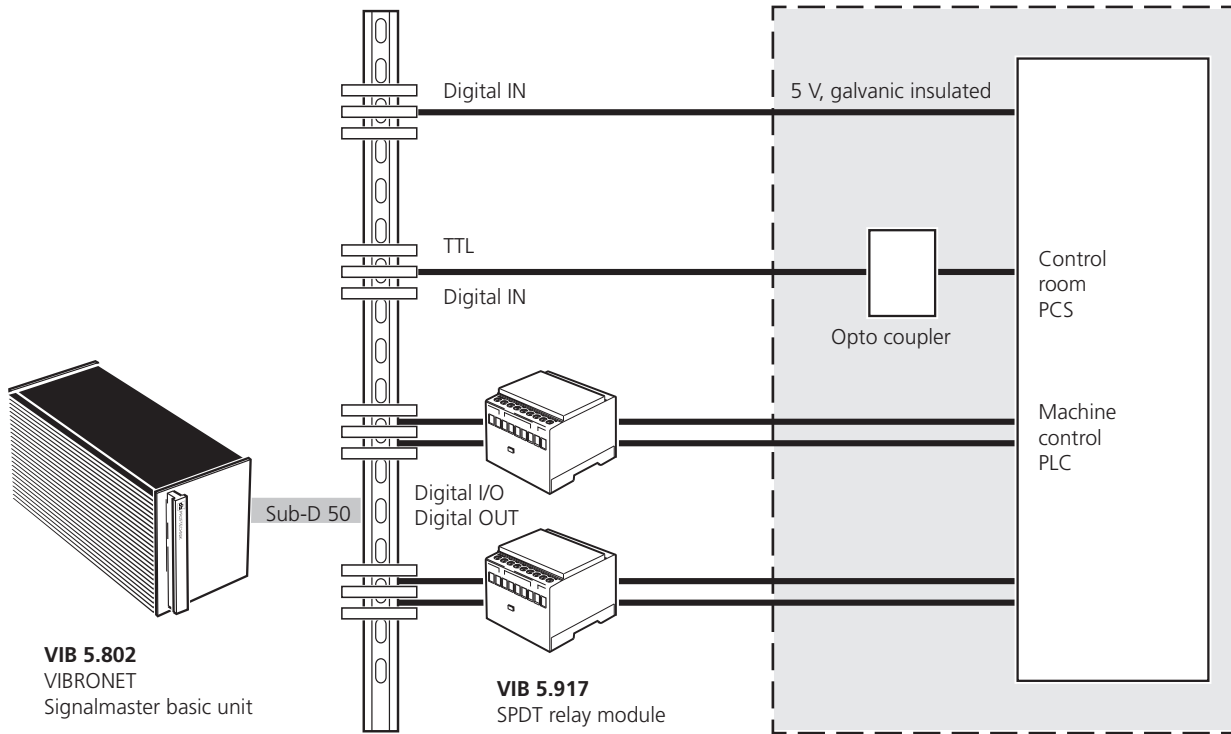

Index by order number

Order no.	Page		Page
VIB 5.802	10	VIB 5.970-M.....	36
VIB 5.812-ICP	28	VIB 5.970-P12	36
VIB 5.815-1	15	VIB 5.970-P24	36
VIB 5.815-3	15	VIB 5.970-P250	36
VIB 5.816	27	VIB 5.972	37
VIB 5.818-N.....	24	VIB 5.973	21
VIB 5.818-NEV.....	24	VIB 5.974-T2	38
VIB 5.819-4x4	24	VIB 5.974-T3	38
VIB 5.819-8x2	24	VIB 5.974-T4	38
VIB 5.883	40	VIB 5.975	39
VIB 5.890-1	8	VIB 8.306	18
VIB 5.890-3	9	VIB 8.306 EX	19
VIB 5.910	29	VIB 8.306 S	18
VIB 5.917	20	VIB 8.306 V	18
VIB 5.920-MOD.....	35	VIB 8.306 XS	19
VIB 5.955-X.....	33	VIB 8.306 XV	19
VIB 5.956-X.....	14	VIB 8.310	17
VIB 5.957-2	33	VIB 8.310 EX	17
VIB 5.957-5	33	VIB 8.312	17
VIB 5.959	32	VIB 8.313	17
VIB 5.962	13	VIB 8.313 EX	17
VIB 5.963	13	VIB 8.314 EX	17
VIB 5.964-1	34	VIB 8.957	40
VIB 5.964-2	34	VIB 8.957-P	40
VIB 5.964-5	34		

PRÜFTECHNIK
Condition Monitoring
Oskar-Messterstr. 19-21
85737 Ismaning, Germany
www.pruftechnik.com
Tel.: +49 8999616-0
Fax: +49 8999616-300
eMail: info@pruftechnik.com



Printed in Germany LIT.58.700.12.2011.EN
VIBRONET®, OMNITREND® are trademarks of PRÜFTECHNIK Dieter
Busch AG. PRÜFTECHNIK products are the subject of patents grant-
ed and pending throughout the world. Contents subject to change
without further notice, particularly in the interest of further techni-
cal development. Reproduction, in any form whatsoever, only upon
express written consent of PRÜFTECHNIK.
© Copyright 2011 by PRÜFTECHNIK AG

Productive maintenance technology